

ROTARY TILLER JUMBO SERIES

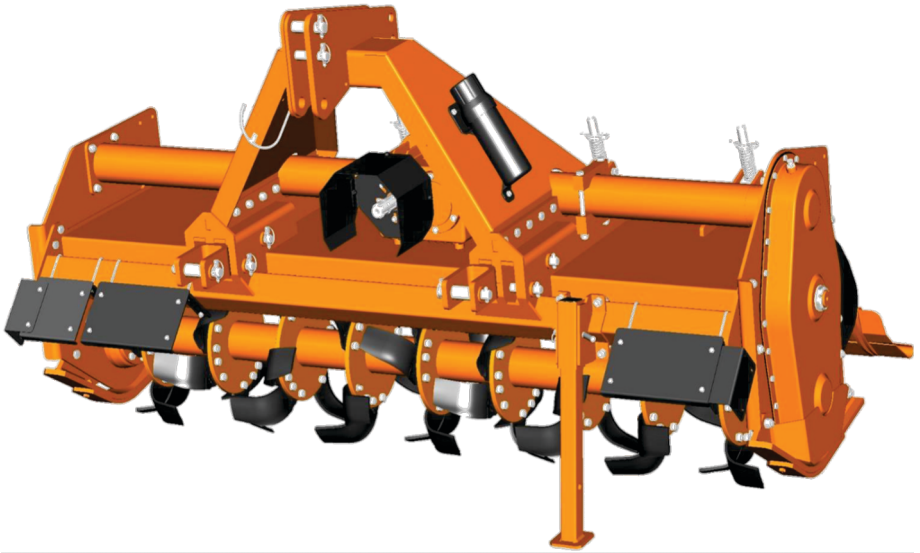

OPERATOR'S AND PARTS MANUAL



Tirth Agro Technology Pvt. Ltd.
ISO 9001:2015 & CE Certified Company

Congratulation for purchasing your new Sundown rotary tiller!

This tiller has been designed and manufactured following all safety and quality requirements needed for a safe and satisfactory use over time.

A careful reading of this manual will permit you to familiarize with your new equipment, and will provide you all the tools needed to use it safely.

A proper maintenance and knowledge of the safety rules of use will allow to obtain the best performance and a long service life of the machine.



The Safety Alert Symbol used throughout this manual and on safety decals of the machine indicates the presence of potential hazard to the operator. When you see this symbol, be alert and carefully read the message that follows it.

The Safety Alert Symbol is used in conjunction with following Signal Words, according to the degree of possible injuries that may result operating the implement:



DANGER

Indicates an imminently hazardous situation that, if not avoided, will result in death or serious injury.



WARNING

Indicates a potentially hazardous situation that, if not avoided, could result in death or serious injury, and includes hazards that are exposed when guards are removed. It may also be used to alert against unsafe practices.



CAUTION

Indicates a potentially hazardous situation that, if not avoided, may result in minor or moderate injury. It may also be used to alert against unsafe practices.

IMPORTANT

Indicates instructions or procedures that, if not observed, can cause damage to equipment or environment.

NOTE

Indicates helpful information.

READ, UNDERSTAND, and FOLLOW the safety messages following the Safety Alert Symbol and Signal Words. Failure to comply with safety messages could result in serious bodily injury or death.

TO THE PURCHASER

This manual contains valuable information about SUNDOWN ROTARY TILLER. It has been carefully prepared to give you helpful suggestions for operating, adjusting, servicing repair parts.

Keep this manual in a convenient place for quick and easy reference. Study it carefully. You have purchased a dependable and sturdy tiller, but only by proper care and operation can you expect to get the service and long life designed and built into it.

RIGHT-HAND AND LEFT-HAND sides are determined by watching from the tractor side.

Sometime in the future your tiller may need new parts to replace those are worn or broken. If so, go to nearest SUNDOWN dealer and provide him the model and part number.

Customer information

Name _____

Purchased from _____

Purchased date _____

Model No. _____

Serial No. _____

Table of Contents

1. ABOUT THIS MANUAL	1
2. INTRODUCTION.....	1
2.1. TILLER IDENTIFICATION	1
2.2. Intended use.....	2
2.3. MAIN PARTS DESCRIPTION.....	3
2.4. TECHNICAL SPECIFICATION	6
3. SAFETY	7
3.1. GENERAL SAFETY INSTRUCTION	7
3.2. EQUIPMENT SAFETY INSTRUCTIONS	8
3.3. OPERATING SAFETY INSTRUCTION	9
3.4. TRANSPORTING SAFETY INSTRUCTIONS.....	10
3.5. MAINTENANCE SAFETY INSTRUCTION	11
3.6. STORAGE SAFETY INSTRUCTIONS.....	11
3.7. SAFETY LABELS.....	12
4. SET UP	16
4.1. LOWER HITCHES POSITIONING.....	16
4.2. CONNECTING TO THE TRACTOR	18
4.3. DRIVELINE INSTALLATION.....	19
4.4. HYDRAULIC CONNECTION	20
4.5. CONNECTION OF ADDITIONAL IMPLEMENTS.....	21
4.6. TRACTOR-TILLER STABILITY	21
5. OPERATING	22
5.1. START UP	22
5.2. OPERATING INSTRUCTIONS.....	24
5.3. ADJUSTMENTS.....	24
5.4. STOPPING AND DISCONNECTION.....	32
5.5. TRANSPORTING	33
6. MAINTENANCE.....	33
6.1. REPLACEMENT OF TOOLS	33
6.2. SCRAPER PLATES REPLACEMENT (PACKER ROLLER).....	36
6.3. GEARBOX LUBRICATION	37
6.4. SIDE CASE LUBRICATION.....	38
6.5. ROTOR BLADES BEARING LUBRICATION.....	38
6.6. REAR ROLLER BEARING LUBRICATION.....	39

6.7. MECHANICAL JACK LUBRICATION	40
6.8. DRIVESHAFT MAINTENANCE	40
7. STORAGE	42
8. SCRAPPING.....	42
9. TROUBLESHOOTING	43
10. TORQUE VALUES TABLE.....	44
11. WARRANTY	45
12. SPARE PARTS.....	47
13. "EC" DECLARATION OF CONFORMITY

1. ABOUT THIS MANUAL

The operator must read the manual for a correct understanding of the hazards that may present when operating the tiller, as well as for obtain optimum performance from the machine.

The manual is part of the machine, it must be kept in good condition and remain with the machine even in case of resale, until its demolition. In case of loss or damage, request a new copy to the Manufacturer or your Dealer.

The information, descriptions and illustrations in this manual describe the state of the product at the time of its publication, and may not reflect the product in the future.

The Manufacturer reserve the right to make design improvements or changes in specifications without incurring in any obligation to install them on units previously sold.

Text, illustrations and drawings of this manual cannot be disclosed or transmitted, in whole or in part, to third parties without the written permission of the Manufacturer. All rights are reserved.

2. INTRODUCTION

2.1. TILLER IDENTIFICATION

Each tiller is provided with a plate for unique identification (see position in picture below), showing the CE marking together with following information:

- Manufacturer name and address
- Product
- Model
- Chassis Serial Number
- Month & Year of manufacture
- Type
- Size/Working Width
- Weight
- Required Size of Prime mower

It's recommended to note down all data shown on the plate.

Any request for assistance or information regarding the machine must be directed to the Manufacturer or Dealer always referring to the model and serial number as shown on the plate affixed to the machine.

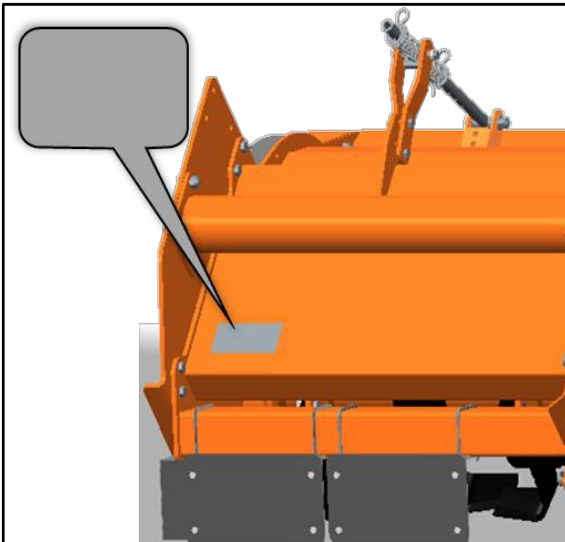

2.2. Intended use

The JUMBO-series tillers are designed specifically for soil tilling, and are intended to be used for preparing the seeding bed - directly or after plowing -, for shuffling stubble and crop residues, perform mechanical weeding and break permanent pastures.

The tillers can be set up in different configuration, depending of the type of work required, through the assembly of optional kits, and are compatible for the fitting with complementary machines (i.e. spreaders, seeding machines).

The tillers are designed to be mounted on tractors equipped with hydraulic lift and universal three-point hitch that can support the implement weight, and driven by the power of the tractor through the PTO driveshaft.

The tractors used to operate the JUMBO-series tillers must have the following requirements:

Hitch Category: 3-point, II - III Category (ISO 730 standard), III Category Quick-Hitch (ASABE S278 standard)

PTO: 540 RPM / 1000 RPM

Horsepower: AS PER TECHNICAL SPECIFICATION TABLE



DANGER

Any use of the machine other than the intended use is non-intended use, and is to be considered as unauthorized and dangerous. The manufacturer assumes no liability for damage resulting from non-intended use.

2.3. MAIN PARTS DESCRIPTION

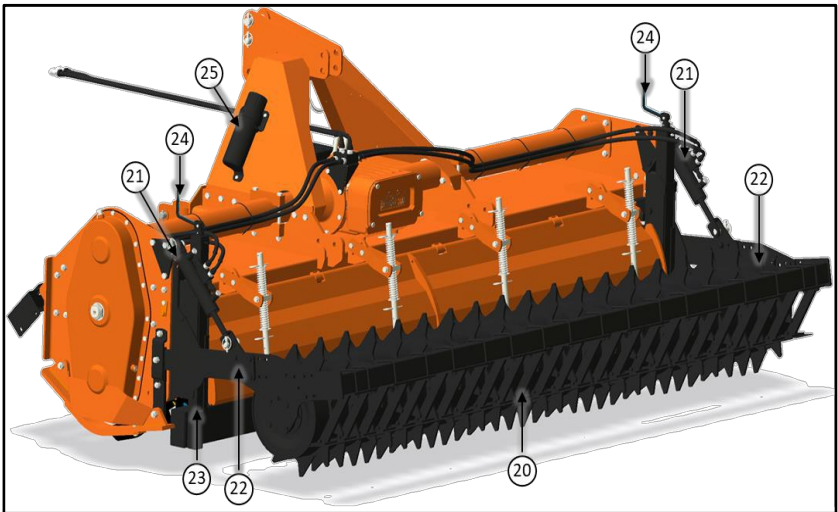
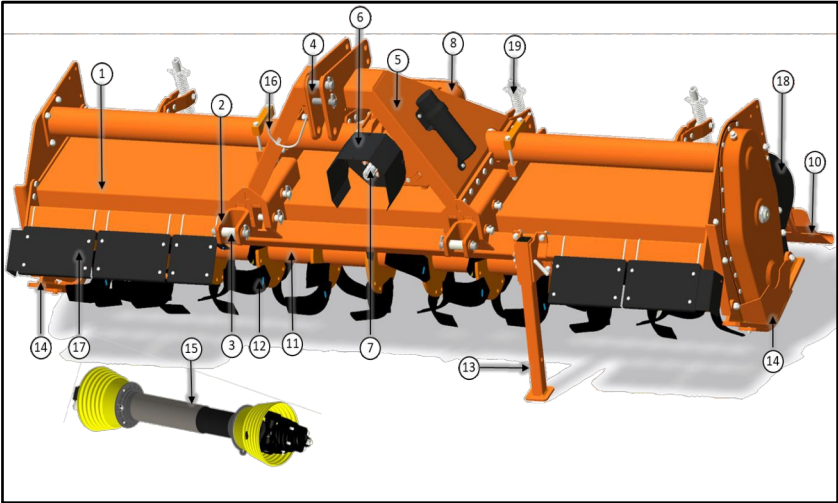



1. Tiller deck	10. Rear leveling board	19. Leveling board adjuster
2. Clevis (lower hitch)	11. Rotor shaft	20. Roller
3. Lower hitch pin	12. Tine	21. Jack for roller adjustment
4. Upper hitch pin	13. Parking stand	22. Lifting arm for roller
5. Top mast	14. Skid	23. Leveling bar
6. PTO shield	15. Cardan driveshaft	24. Jack for leveling bar adjustment
7. Implement Input Connection	16. Driveshaft hook	25. Manual Container
8. Gearbox	17. Front barrier	
9. Side transmission case	18. Side barrier	

NOTE

To make the illustrations more clear, some images of this manual may refer to machines lacking of some components (e.g. safety devices and barriers).

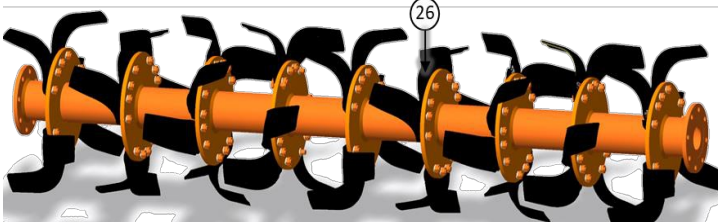
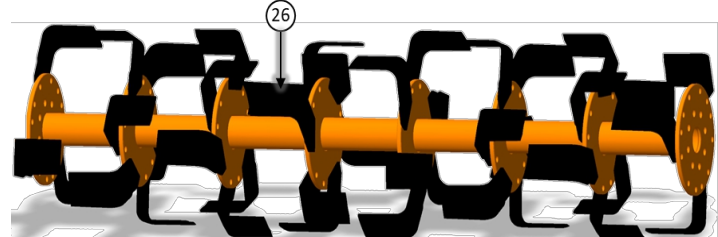
ROTORS

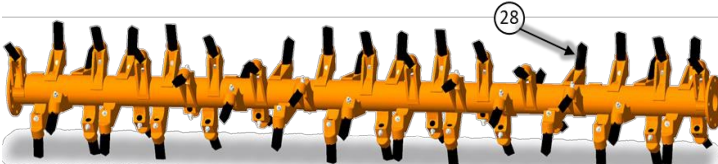
 A 3D illustration of a rotor assembly with a central orange shaft and several black curved tines. A callout circle with the number 26 points to one of the tines.	Tines rotor ("A" type)
 A 3D illustration of a rotor assembly with a central orange shaft and several black curved tines. A callout circle with the number 26 points to one of the tines.	Tines rotor ("B" type)
 A 3D illustration of a rotor assembly with a central orange shaft and many small black blades. A callout circle with the number 27 points to one of the blades.	Blades rotor (to use with leveling bar)
 A 3D illustration of a rotor assembly with a central orange shaft and many small black spikes. A callout circle with the number 28 points to one of the spikes.	Spikes rotor
<p>26. Tine 27. Blade 28. Spike</p>	

Rear Rollers (OPTIONAL)

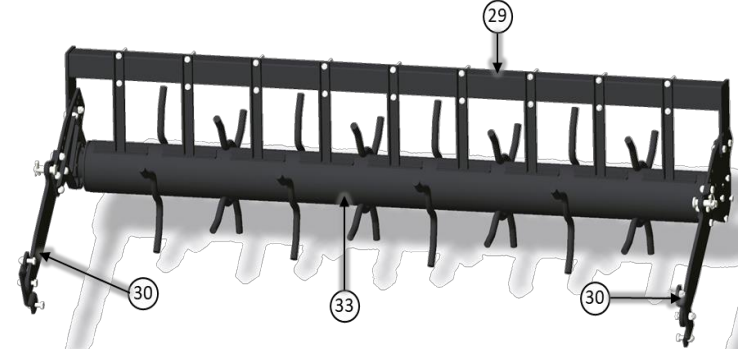
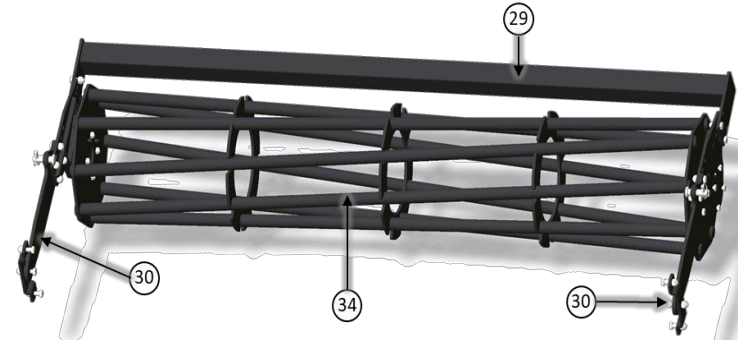
	<p>Packer Roller (D=450; D=500)</p>
	<p>Spike Roller (D=490; D=540)</p>
	<p>Cage Roller (D=400; D=450)</p>
<ul style="list-style-type: none"> 29. Roller frame 30. Lifting arm 31. Scraper plate 32. Packer roller 33. Spike Roller 34. Cage Roller 	

2.4 TECHNICAL SPECIFICATION

Model	Unit	JUMBO 200	JUMBO 250	JUMBO 300			
Overall dimensions	mm	2300 x 1200 x1400	2800 x 1200 x1400	3300 x 1200 x 1400			
Working width	mm	2100	2600	3100			
	inch	82	102	122			
Tractor power	HP. / kw	60-90 / 45-67	90-120 / 67-89	100-140 / 75-104			
3-point Hitch type	-	II - III Category (ISO 730 standard),					
		III Category Quick-Hitch (ASABE S278 standard)					
PTO Input speed	rpm	540 / 1000					
Rotor Shaft Speed	rpm	As per rotor speed table.					
Side transmission type	-	gears					
Working depth (max)	mm	130					
Rotor tube diameter	mm	115					
Rotor Swing Diameter	mm	530					
Driveline safety device	-	Slip Clutch / Driveshaft W/Automatic Clutch (Optional)					
Weight – with "Standard Tine (Square / Curved) " type rotor (*)	Kg. / lbs	934 / 2059	1061 / 2339	1167 / 2573			
Square / Curved Type	Nos.	48	60	72			
Spikes rotor	Nos.	40	50	60			
"Straight" Blades rotor	Nos.	68	84	100			
Packer roller							
Overall dimension	cm	215 x 60 x 48	215 x 60 x 60	265 x 60 x 48	265 x 60 x 60	315 x 60 x 48	315 x 60 x 60
Diameter	mm	450	500	450	500	450	500
Weight (**)	Kg / lbs	320 / 705	303 / 668	378 / 833	356 / 785	434 / 957	410 / 904
Cage roller							
Overall dimension	cm	215 x 57 x 43	215 x 48 x 61	265 x 57 x 43	265 x 48 x 61	315 x 57 x 43	315 x 48 x 61
Diameter	mm	400	450	400	450	400	450
Weight (**)	Kg / lbs	161 / 355	200 / 441	180 / 397	227 / 500	196 / 432	247 / 545
Spike roller							
Overall dimension	cm	215 x 50 x 62	215 x 61 x 52	265 x 50 x 62	265 x 61 x 52	315 x 50 x 62	315 x 61 x 52
Diameter	mm	490	540	490	540	490	540
Weight (**)	Kg / lbs	175 / 386	185 / 408	201 / 443	214 / 472	227 / 500	243 / 536
Levelling bar							
Weight	kg	70		78		86	
(*) roller and driveshaft excluded		(**) roller frame with hydraulic jack included					

3. SAFETY

Proper use of the equipment, a strict observance of the safety messages listed below and application of all reasonable practices to avoid any risks, prevents accidents or injury, allows the machine working better and longer, and minimize the failures.

The manufacturer assumes no liability for any damage resulting from not applying the behavioral rules indicated into the manual.

3.1. GENERAL SAFETY INSTRUCTION

 **DANGER**

The machine must be used only by authorized and well-trained operators. The operator must have read and understood the instructions of this manual, it must make adequate preparation for the proper use of the machine and must hold a driving license. In case of doubt about the use of the machine and/or the interpretation of this manual, the operator must contact the Manufacturer or the Dealer.

 **WARNING**

The manual must always remain with the machine. In case of loss or damage, request a new copy to the Manufacturer or your Dealer.

 **WARNING**

Follow strictly the rules prescribed by the safety pictograms applied to the machine.

 **WARNING**

Be sure that all safety pictograms are legible. If pictograms are worn, they must be replaced with others obtained from the Manufacturer, and placed in the position indicated by this manual.

 **DANGER**

Before using the machine, make sure that all safety devices are installed and in good working conditions. In case of damages of shields, replace them immediately.

 **DANGER**

Is absolutely forbidden to remove or alter safety devices.

 **DANGER**

Before starting, and during operation of the tiller, make sure there are no people or animals in the operation area: the machine can project material from the back, with risks of serious injury or death.

 **DANGER**

Pay maximum attention to avoid any accidental contact with rotating parts of the machine.

 **DANGER**

During operation, adjustment, maintenance, repairing or transportation of the machine, the operator must always use appropriate Personal Protective Equipment (PPE).

 **DANGER**

Do not operate the implement while wearing loose fitting clothing that can give rise to entanglement in parts of the machine.

 **DANGER**

Do not operate the implement when tired, not in good condition or under the influence of alcohol or drugs.

**CAUTION**

If the use of the machine is required at night or in conditions of reduced visibility, use the lighting system of the tractor and possibly an auxiliary lighting system.

3.2. EQUIPMENT SAFETY INSTRUCTIONS**WARNING**

Use the tiller for its intended purpose only. Improper use can damage the tiller and cause serious injury to persons, animals, or death.

**DANGER**

The machine should be used by a single operator driving the tractor.

**WARNING**

Any unauthorized modification of the machine may cause problems in safety and relieves the Manufacturer from any liability for damages or injuries that may result to operators, third parties and objects.

**WARNING**

Before using the machine, familiarize yourself with its controls and its working capacity.

**WARNING**

Do not leave the tiller unattended with tractor engine running.

**WARNING**

Do not operate tiller on too muddy, sandy or rocky soils.

**WARNING**

Keep the machine clean from debris and foreign objects which may damage functioning or cause injury.

**WARNING**

Do not use the machine if the category of the connecting pins of the tiller does not match that of the tractor hitch system.

**WARNING**

Do not use the machine with missing bolts, screws, pins or safety pins.

**WARNING**

Never use the machine to transport or lift people, animals or objects.

**WARNING**

Make certain, by adding front ballast, that at least 20% of the total weight (tractor, implement and ballast) is on the front axle of the tractor, to ensure stability.

**WARNING**

Before engaging the tractor PTO, make sure the tractor PTO speed is set as required for the tiller (540 or 1000 rpm). Do not over speed PTO or machine breakage may result.

**DANGER**

Do not operate the tiller if the driveshaft is damaged. The driveshaft could be subject to breakage during operation, causing serious injury or death. Remove the driveshaft and replace it with an undamaged.

 **DANGER**

With tiller disconnected from tractor, rest the driveline on the provided support of the tiller.

3.3. OPERATING SAFETY INSTRUCTION

 **WARNING**

Before using the machine, be sure to have cleared the operating area from obstacles (stones, branches, debris, etc...). Mark all the obstacles that cannot be eliminated (e.g. by means flags).

 **DANGER**

Never engage the tractor PTO in the presence of people close to the driveshaft. The body, hair or clothing of a person can get caught in rotating parts, causing serious injury or death.

 **DANGER**

Before engaging the PTO and during all operations, make sure that no person or animal is in immediate area of action of the machine. Never use the tiller if people are in his working area.

 **DANGER**

It's absolutely forbidden to stand near the tiller with moving parts.

 **WARNING**

The operator must operate tiller lifting/lowering only from the driving seat of the tractor. Do not perform lifting maneuvers on side or behind the tractor.

 **WARNING**

Before making changes in direction, turns or going in reverse, slightly lift the tiller from the ground after disengaging the power take-off, to avoid damage to the machine.

 **DANGER**

In presence of steep slopes (greater than 15 degrees) the tilling action may cause instability of the tractor, with risk of tipping and consequent serious injury or death hazard. Consult the manual for the tractor to determine the maximum slope that the tractor is able to deal with.

 **DANGER**

Always disengage the PTO before raising the tiller, and never engage the PTO with the tiller in the raised position. The machine might throw objects at high speed, causing serious injury or death.

 **WARNING**

Never leave the driver's seat when the tractor is turned on. Before leaving the tractor, lower the tiller to the ground, disengage the PTO, insert the parking brake, stop engine and remove the key from the control panel.

 **DANGER**

The PTO shields of tractor and implement side, the driveshaft shielding and the driveshaft retaining chains must be properly installed and in good condition, to avoid risk of entanglement with serious injury or death.

 **DANGER**

Before engaging the PTO of the tractor, always make sure that the drive shaft is mounted in the correct direction, and that its clamping elements are properly connected both to tractor side and to tiller side.

 **WARNING**

Stop operating immediately if blades strike a foreign object. Repair all damage and make certain rotor and blades are in good condition before resuming operation.

 **WARNING**

Always disengage the tractor PTO when the driveshaft exceeds an angle of 10 degrees up or down while operating. An excessive angle with driveshaft rotating can break the driveshaft and cause flying projectiles.

 **CAUTION**

Avoid clutch's overheating caused by too long or frequent slipping of the clutch, since it can damage the clutch components. Before checking slip clutch, make sure it has cooled. Clutch could be extremely hot and cause severe burn.

 **CAUTION**

Prolonged use of the tiller can cause overheating of the gearbox. Do not touch the gearbox during use and immediately after, it could be extremely hot and cause severe burn.

 **WARNING**

All adjustment operations on the tiller must be performed by qualified and trained operators, with the tractor engine off, the PTO disengaged, the tiller lowered to the ground or on security stands, the ignition key off and the parking brake set.

3.4. TRANSPORTING SAFETY INSTRUCTIONS

 **WARNING**

Before transporting, determine the stopping characteristics of the tractor and implement.

 **WARNING**

Transport only at speeds where you can maintain control of the equipment.

 **WARNING**

When driving on roads, the implement must be in transport position adequately raised from the road surface, with tractor lifting hydraulics locked so that the tiller cannot be lowered accidentally.

 **DANGER**

The implement may be wider than the tractor. Pay attention during transporting to persons, animals or obstacles exposed.

 **WARNING**

When turning, use extreme care and reduce tractor speed.

 **WARNING**

Do not operate the tractor with weak or faulty brakes or worn tires.

 **CAUTION**

Always use tractor lighting system and auxiliary lighting system for an adequate warning to operators of other vehicles, especially when transporting at night or in conditions of reduced visibility.

 **DANGER**

In case of tiller lifting, make sure that the lifting device chosen is suitable to perform the operation safely, and use only the lifting points prescribed on tiller.

3.5. MAINTENANCE SAFETY INSTRUCTION

 **WARNING**

All maintenance and repairing operations must be performed by qualified and trained operators, with the tractor engine off, the PTO disengaged, the tiller lowered to the ground or on security stands, the ignition keys off and the parking brake set.

 **WARNING**

Perform repairs and replacements necessary to the machine using only original spare parts provided by the manufacturer or your Dealer.

 **DANGER**

Perform maintenance operations always using appropriate Personal Protective Equipment (protective eye glasses, hard hat, hearing protection, safety shoes, overall and work gloves, filter mask).

 **CAUTION**

Before any maintenance operation, make sure that the parts which may become hot during use (friction clutch, gear box...) have cooled.

 **WARNING**

Do not perform repairs that you do not know. Always follow the manual instructions and in case of doubt contact the Manufacturer or your Dealer.

 **DANGER**

Do not swallow fuels or lubricants. In case of accidental contact with eyes, rinse well with water and consult a doctor.

3.6. STORAGE SAFETY INSTRUCTIONS

 **WARNING**

Never leave the tractor unattended with the tiller in lifted position. Accidental operation of lifting lever or a hydraulic failure may cause sudden drop of unit with injury or death by crushing.

 **DANGER**

Following operation, or before unhooking the tiller, stop the tractor, set the brakes, disengage the PTO, lower the attached tiller to the ground, shut off the engine, remove the ignition key and wait for all moving parts to stop.

 **WARNING**

Make sure all parked machines are on a hard, level surface and engage all safety devices.

 **CAUTION**

Place support blocks under tiller as needed to prevent unit from tipping over onto a child and/or an adult. A tiller that tips over can result in injury or death.

 **CAUTION**









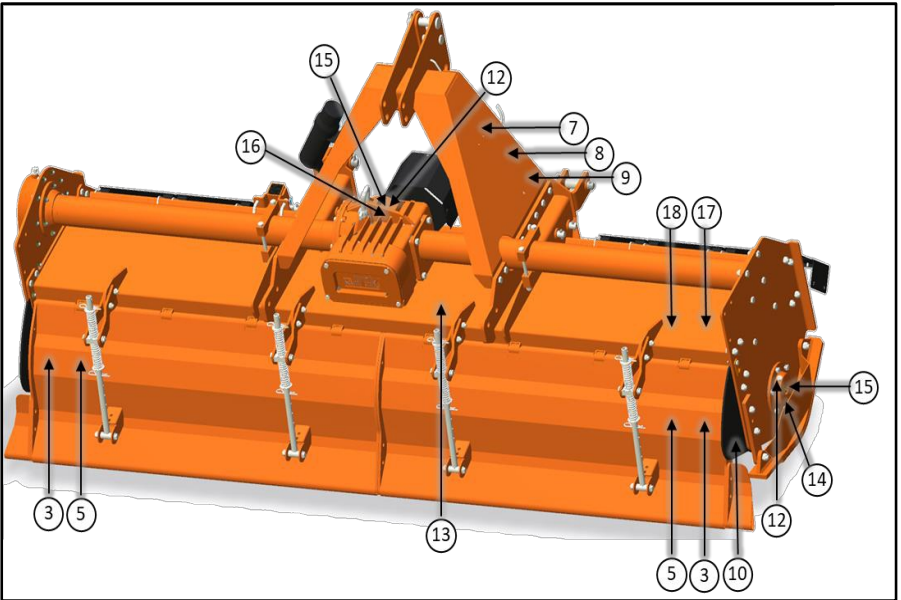
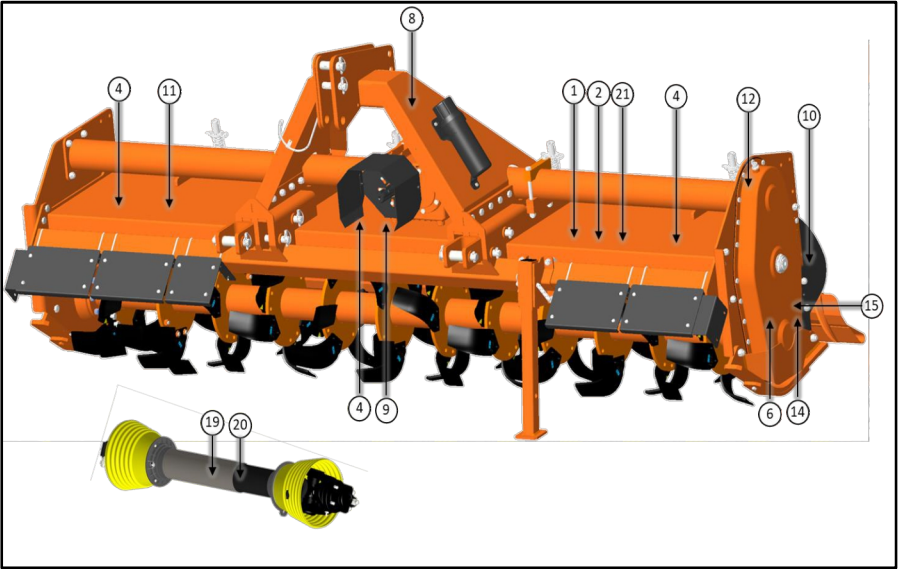







Store the unit in an area away from human activity.

3.7. SAFETY LABELS





The safety labels applied on the machine give fundamental information for using the machine safely. Make sure safety labels are in good conditions. If pictograms are worn, they must be replaced with others obtained from the Manufacturer and placed in the position indicated by this manual. Make sure the safety labels are legible. If necessary, wipe them by a cloth, with soap and water.

SAFETY LABELS POSITION AND DESCRIPTION

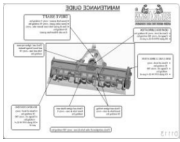

Sr. NO.	SPARE CODE	DESCRIPTION	DECALS
1	D1090	WARNING: ALWAYS READ THE OPERATOR MANUAL	 
2	D1038	MAINTENANCE: TURN OFF TRACTOR& REMOVE KEY	 
3	D1095	THROWN OR FLYING OBJECTS HAZARD	 
4	D1096	ROTATING KNIVES, LOWER LIMBS HAZARD	 
5	D1078	HAND HAZARD	 
6	D1079	ROTATING GEARS	 
7	D1097	CRUSHING HAZARD BY LINK LIFTING	 
8	D1098	IMPLEMENT INPUT DRIVELINE	 

9	D1099	TRACTOR PTO RPM & ROTATION DIRECTION																															
10	D1122	FINGERS/HANDS CRUSHING HAZARD																															
11	D1082	SAFETY EQUIPMENT																															
12	D1007	OIL FILLING PLUG																															
13	D1110	SPEED CHART JUMBO	 <table border="1" data-bbox="802 799 951 945"> <thead> <tr> <th>PTO SPEED</th> <th colspan="2">540 RPM</th> <th colspan="2">1080 RPM</th> </tr> </thead> <tbody> <tr> <td>2:21</td> <td>2:21</td> <td>2:17</td> <td>2:17</td> <td>2:17</td> </tr> <tr> <td>2:22</td> <td>2:22</td> <td>2:18</td> <td>2:18</td> <td>2:18</td> </tr> <tr> <td>2:15</td> <td>2:15</td> <td>2:15</td> <td>2:15</td> <td>2:15</td> </tr> <tr> <td>2:17</td> <td>2:17</td> <td>2:21</td> <td>2:21</td> <td>2:21</td> </tr> <tr> <td>2:18</td> <td>2:18</td> <td>2:22</td> <td>2:22</td> <td>2:22</td> </tr> </tbody> </table>	PTO SPEED	540 RPM		1080 RPM		2:21	2:21	2:17	2:17	2:17	2:22	2:22	2:18	2:18	2:18	2:15	2:15	2:15	2:15	2:15	2:17	2:17	2:21	2:21	2:21	2:18	2:18	2:22	2:22	2:22
PTO SPEED	540 RPM		1080 RPM																														
2:21	2:21	2:17	2:17	2:17																													
2:22	2:22	2:18	2:18	2:18																													
2:15	2:15	2:15	2:15	2:15																													
2:17	2:17	2:21	2:21	2:21																													
2:18	2:18	2:22	2:22	2:22																													
14	D1009	OIL DRAIN PLUG																															
15	D1006	MAINTAIN OIL LEVEL																															
16	D1083	LIFTING HOOK JOINT																															

17	D1113	MAINTENANCE GUIDE	
18	D1108	CE LOGO	
19	D1123	ROTATING DRIVELINE (COVER)	
20	D1124	ROTATING DRIVELINE (TUBE)	
21	D1092	DO NOT RIDE ON PLATFORM, KEEP DISTANCE	

4. SET UP

The tiller is delivered equipped with a driveshaft with torque limiter (clutch discs) and related operating manual.

When the machine is delivered, check that there is no damage to the tiller or driveshaft. In case of damage or missing parts immediately notify the Manufacturer or your Dealer.

Because of its size, the tiller could be delivered with some parts to be assembled (in particular, the EC safety guards).

In this case, the assembly of such parts is an owner's task, and must be performed carefully, with reference to the tables of the Spare parts section.

ATTENTION

For proper tightening torques of bolts and screws, refer to the table in this manual.

4.1. LOWER HITCHES POSITIONING

The JUMBO tillers are designed to be mounted on tractors equipped with:

- 3-point Hitch Category II (ISO 730 standard);
- 3-point Hitch Category III (ISO 730 standard);
- 3-point Quick Hitch Category III (ASABE standard).

The position of the lower hitches must be adjusted accordingly.

If the tractor is equipped with a 3-point Hitch Category II (ISO 730 standard):

- verify that the lower clevises are equipped with II Category pins (D=28 mm) and are inserted into the inner slots, as shown in the picture below;
- Verify that the II Category pin (D=25.7 mm) is positioned on the middle hole of the mast plate (see picture).

The distance between the upper pin and the lower pins must be consequently of 610 mm (24"), as required from the standard (see picture):

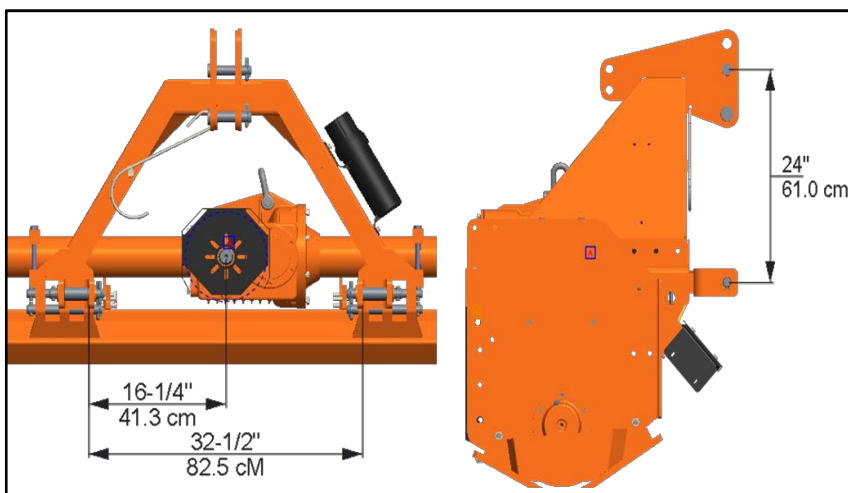

If the tractor is equipped with a 3-point Hitch Category III (ISO 730 standard):

- Verify that the lower clevises are equipped with II Category pins with related adapting bushing (D=36 mm), and are inserted into the outer slots, as showed in the picture below;
- Verify that the III Category pin (D=32 mm) is positioned on the top hole of the mast plate (see picture).

The distance between the upper pin and the lower pins must be consequently of 685 mm (27"), as required from the standard (see picture):

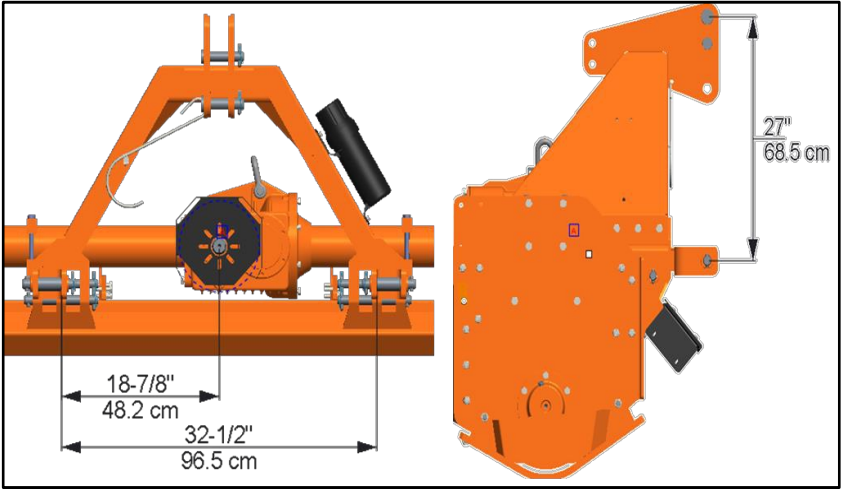

If the tractor is equipped with a 3-point Quick Hitch Category III (standard ASABE):

- verify that the lower clevises are equipped with II Category pins with related adapting bushing (D=36.6 mm), and are inserted into the outer slots, as showed into the picture below;
- Verify that the III Category pin (D=32 mm) is positioned on the lower hole of the mast plate (see picture).

The distance between the upper pin and the lower pins must be consequently of 460 mm (18"), as required from the standard (see picture):

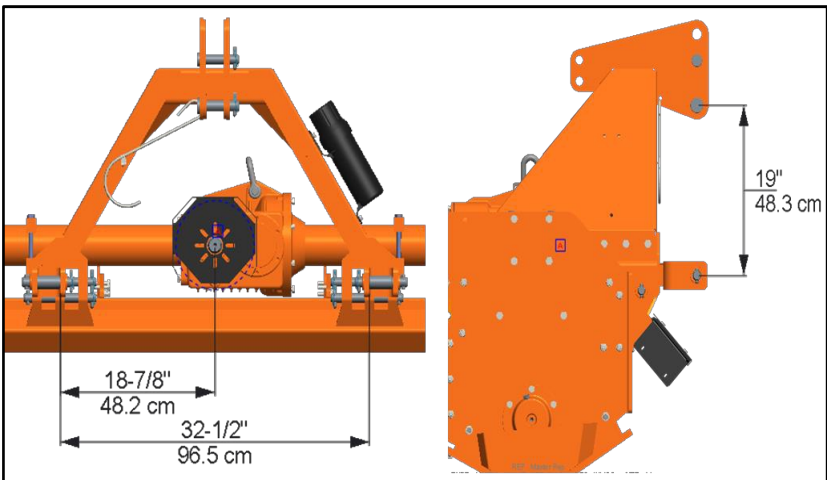

When a change from II to III Category configuration (or vice-versa) is required on the tiller, the operator must:

- pull out the safety pins (1) (see picture below);
- extract pins (2);
- extract lower clevises (3) and change their position, from the inner to the outer slots (or vice-versa);
- replace pins and safety pins in their original position;
- install the adapting bushing on the lower pins (vice-versa, remove the bushing from the pins to change from III to II Category);
- Remove the II Category pin D36.6 from the middle hole of the mast plate, and insert the III Category pin D32 into the top hole (or into the lower hole for the Quick Hitch). Do the opposite to change from III to II Category.

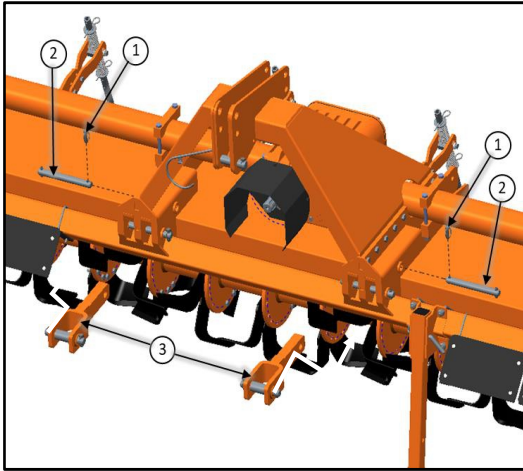

4.2. CONNECTING TO THE TRACTOR



WARNING

Before connect the tiller to the tractor, make sure that tractor and tiller are on a flat, stable and dry surface.

To connect the tiller to the tractor the operator must do the following:

- drive the tractor in reverse, up to align the rear lifting arms to lower hitches of the tiller in parking (see the picture below);

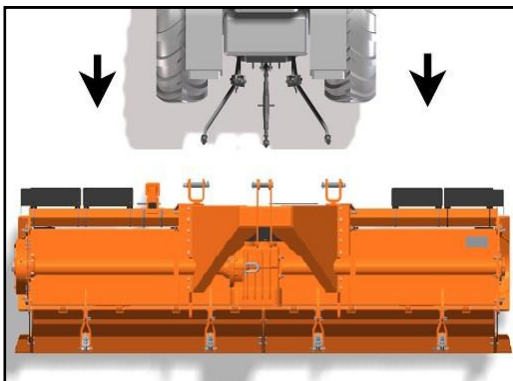

-
- set the tractor's parking brake, stop engine, remove the ignition key and get off the tractor;
 - connect the lifting arms of the tractor to the lower hitches of the tiller, through the use of the pins and the relative safety split pins;
 - raise the tiller until PTOs of tractor and machine are at the same height, then adjust the 3-point top link so that the front of the machine is leveled to the back (the axis of the tiller PTO must be parallel to the ground), in order to limit stress transmitted to the tiller through the cardan shaft;
 - make sure that left side of the tiller is leveled with the right, by adjusting the tractor lifting arms, then lock the arms to prevent swinging that could compromise the stability of tractor and machine;
 - finally adjust the parking stand, placing it at the highest point by means of the related elastic pin.

4.3. DRIVELINE INSTALLATION

Before installing the driveshaft, the operator must read the manuals of driveshaft and tractor, checking in particular that rpm and direction of rotation of the tractor PTO match those of the tiller.

If the direction of rotation of the PTO tractor does not match that of the tiller, contact the Manufacturer or your Dealer.

To connect the driveshaft to the tractor and implement, the operator must:

- park tractor and tiller on a flat surface, with parking brake set, engine off, and ignition key removed;
- check that safety devices of driveshaft, tiller and tractor are in good condition, otherwise provide for their replacement;
- remove the PTO shield of the tiller through the fixing screws;
- position the driveshaft with clutch turned towards the implement side;
- insert the clutch hub on the tiller PTO, then ensure its tightening onto shaft through its fastener;
- replace the PTO shield of the tiller through the fixing screws;
- insert the driveshaft yoke on the tractor PTO, then ensure its tightening onto shaft through its fastener;
- hook to the tractor and tiller the two retaining chains of the driveline shielding, to prevent shielding rotation during functioning of the machine.

DRIVELINE LENGTH CHECK

Before operating the tiller, ensure that the size of driveshaft is adequate. The driveshaft supplied with the machine has a standard length; therefore, it may need an adaptation of the length, depending of the tractor which the tiller is combined.

The length of the driveshaft must be such to:

- avoid bottom out of the transmission tubes, when the driveshaft is in compressed position (when tiller is raised up off the ground);
- ensure an overlapping of the transmission tubes enough to transmit the torque required, when the driveshaft is in max extension (when tiller is in its lowest position in the ground).

When the driveshaft is at its minimum length (max compressed position), there must be at least a 2 cm of distance between the ends of each transmission tube and the yokes side.

When the driveshaft is at its maximum operational extension, there must be an overlap between the tube's profiles of 15 cm at least.

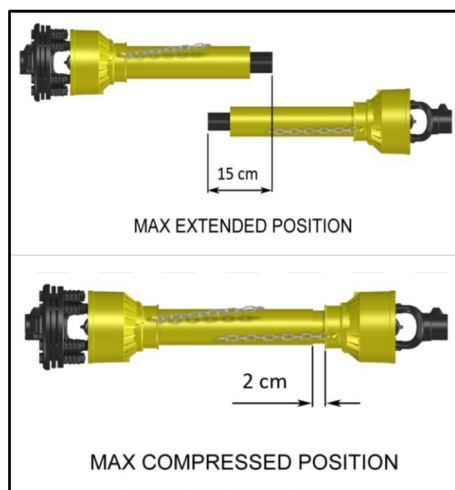

A driveshaft too long may cause structural damages to the tractor and machine. If the driveshaft is too long, it may be adapted by removing it and shortening the tubes according to the instructions provided by the Manufacturer in its use and maintenance manual.

A driveshaft too short can cause disengage of the tubes during operation, with severe hazard for the operator and structural damage to the tractor and machine. If the driveshaft is too short, it must be replaced with a longer one. In this case contact the Manufacturer or your Dealer.

IMPORTANT

- before operating the tiller, the first time, make sure that the driveshaft is lubricated in accordance with how indicated in the instruction booklet;
- before operating the tiller, the first time, and after long periods of inactivity, make sure that the driveline clutch has run a short "run in" in accordance with what indicated in the instruction manual of the Manufacturer, removing the possible oxidation of the components that may compromise the correct slipping during the usage (see also section "Maintenance");
- always engage the tractor PTO at low rpm to minimize the effect of the peak torque on the driveline and the machine.

4.4. HYDRAULIC CONNECTION

If the machine is equipped with a rear roller with hydraulic cylinders, it is necessary to connect the machine hydraulics to the tractor to allow the appropriate adjustments of the roller (lifting and lowering).

To make the connection the operator must press vigorously the hydraulic hoses with quick coupling into the corresponding seats of the tractor, until the connection is done (see picture):

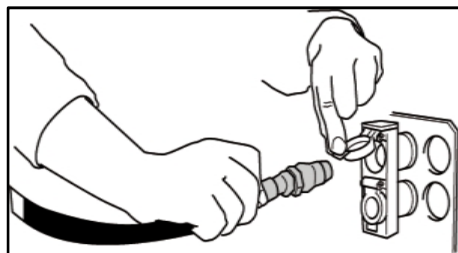



WARNING

Check the hydraulic pipes frequently and replace them whenever they show signs of wear or if small cracks form in the rubber.



WARNING

Before carrying out operations on hydraulic lines under pressure or disconnecting hydraulic components, ensure the line has been previously depressurized and does not contain any hot fluid.

4.5. CONNECTION OF ADDITIONAL IMPLEMENTS

The tiller can be combined with other machines that complete his work, like fertilizers spreaders or seeders.

In this case, to realize the connection of the above implements to the tiller, the operator must proceed in a manner similar to how described for the connection of the tiller to the tractor, performing the following operations:

- connection of the implement 3-point link to the tiller frame;
- connection of the additional driveshaft from implement to the tiller;
- connection of the implement hydraulic lines to the tractor.

Always refer to the Operators Manuals of the implements to perform correctly the operations.

The maximum working speed of the tractor when the tiller is equipped with additional implements must not exceed 3 km/h in order to avoid breakage or damage.



WARNING

If additional implements are used combined to the tiller, keep much attention to the risks that may be generated during the phases of connection, use and disconnection of the implements.

All maintenance and repairing operations must be performed by qualified and trained operators, with the tractor engine off, the PTO disengaged, the tiller lowered to the ground or on security stands, the ignition keys off and the parking brake set.

4.6. TRACTOR-TILLER STABILITY

Before connecting the machine to the tractor is required to check the stability of the tractor-machine system, in order to determine the ballast to apply to the front of the tractor, to ensure adequate distribution of the weight on the axles.

In order to assure the stability, it is necessary that the following relations are verified (see table below for definitions):

$$1) M \times (S1+S2) \leq 0.2 \times T \times i + Z \times (d+i)$$

$$2) M \leq 0.3T$$

Consequently, the minimum ballast required is:

$$Z \text{ min} = (M \times (S1+S2) - 0.2 \times T \times i) / (d+i).$$

To determine the appropriate characteristics of the ballast, refer to the manual of the tractor.

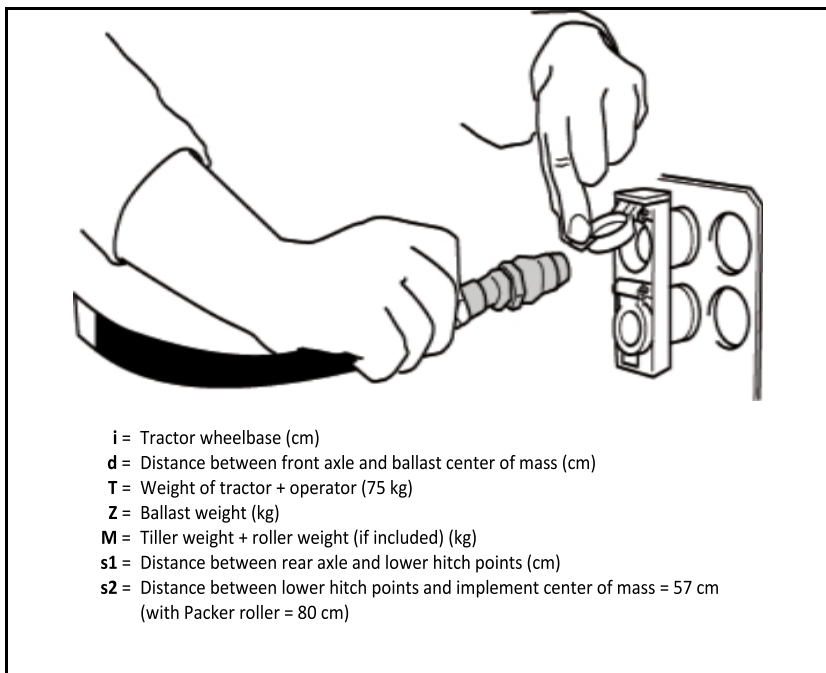

If the tiller is combined with other machines (fertilizers spreaders or seeders), the ballast check must be done considering:

M = total weight of the implements (tiller + roller + spreader/seedler)

$S2$ = Distance between lower hitch points and center of mass of implements
 (tiller + roller + spreader/seedler)

 **CAUTION**

The weight of the machine modifies the stability of the system tractor-tiller, resulting in loss of steering control and braking.

5. OPERATING

Before operate the tiller, make sure you have read and understood the operating manuals of the tiller, tractor and PTO shaft, and followed what is described in the section "Set Up".

 **DANGER**

During operation, adjustment, maintenance, repairing or transportation of the machine, the operator must always use appropriate Personal Protective Equipment (PPE).

Before starting work, ensure that all machine guards are in good conditions and fully functional.

During operation, the machine can throw material from the back: prevent people and animals to approach the operational area.

5.1. START UP

Before the start up and before each use, perform the following pre-operation inspections and service of the implement:

-
- check that the tiller has not damaged functional parts and has all mechanical parts in good condition. Repair and / or replace the damaged parts;
 - check that the tiller has no missing parts (pins, safety pins, plugs oil ...). Restore the missing parts;
 - check that all guards and safety devices have no damages and are properly positioned. Repair and / or replace the damaged shielding's, restore the correct position;
 - verify that the PTO driveshaft is properly installed (see section: Connection of the drive shaft);
 - check that the driveshaft clutch is in good condition, and that its components are not subject to "sticking" (see sections: Maintenance / Driveline);
 - check the presence of lubricant in all greasing points of the tiller (driveshaft, supports...) (see sections: Maintenance / Driveline and Maintenance / Support rotor);
 - check for oil leaks from the gearbox or the transmission side cover. Identify the reason of loss, then repair and / or replace the damaged components;
 - check the correct oil level in the gearbox and in transmission side box (see section maintenance);
 - check that blades are not excessively worn and the relating hardware is correctly tightened (see section Maintenance);
 - check that all the tiller hardware is properly tightened. Refer to the tightening table in the manual for proper torque values;
 - check that all safety decals are correctly positioned, in good condition and legible. Replace any damaged decals;
 - check that there are no constraints that may prevent the movement of equipment. Remove any constraint. Before the start up and before each use, make the following checks on the operating area identified for tillage:
 - check that area is clear of foreign objects (rocks, branches or debris). Remove any obstacle and visibly highlight obstacles that cannot be eliminated (e.g. by means flags);
 - make sure in the working area exposed there are no people or animals;
 - make sure the soil to be worked is not too grassy, muddy, sandy or rocky.



WARNING

Before conducting the above inspections and service, make sure the tractor engine is off, all rotation parts are completely stopped and the tractor is in park with the parking brake engaged. Make sure the tiller is resting on the ground or securely blocked up and the tractor lifting hydraulics locked.

Once all the checks above have been done, start tractor and the tiller as follows:

- start the tractor and engage the tractor PTO at low rpm, making sure that the tiller is NOT in the raised position but close to the ground, then increase speed engine until to 540 rpm or 1000 rpm, according to the tractor model and the gears set into the gearbox (see section "Gearbox speed adjustment");
- lower the tiller on the ground and simultaneously start driving the tractor at low speed. Subsequently increase the ground speed depending on ground conditions;
- If the environmental temperature is very cold, it's recommended to wait a few minutes with the PTO of the tractor at low rate before lowering the tiller completely on the ground;
- drive for a while operating the tiller, then stop the tractor to check the quality of the work performed. If you need to get off the tractor, lift the tiller just out of the ground, reduce engine speed and disengage PTO, set the parking brake, stop engine and remove the ignition key;

If the working depth and/or soil texture are not as desired, correct them by adjusting the skids and the roller (if included), and/or the rear cover (see sections "Leveling boards adjustment" and "Rear roller adjustment").

5.2. OPERATING INSTRUCTIONS

During operations:

- always keep the tractor engine at rpm rate ensuring to the tiller the right power required for the use;
- always keep a tractor speed adequate to conditions of the soil to be worked (from 2 to 10 km/h approx.). Reduce speed in the case of hard or stony soils;
- choose a driving pattern that provides the maximum pass length and minimizes turning;
- when working in the hills, if you can do "climbing" in the sense of the slope, in any case do not work along the hillsides, making the steps from top to bottom to reduce the terrace. Where possible always try to «work up» the slope. If this is not possible, avoid hoeing along the contours of the hill and hoe up and down the slope to avoid a terracing effect;
- always perform changes and reverse of direction with PTO disengaged and the tiller slightly lifted from the ground to avoid damage to the machine;
- periodically check for foreign objects wrapped around the rotor shaft and remove them, after disengaging PTO, turning off tractor engine, and removing ignition key;
- if the blades strike a foreign object, or in case of prolonged intervention of the clutch due to an object wedged into the rotor, stop operating immediately, idle the engine speed and disengage the PTO. Wait for stopping of all rotating parts, then raise the implement and proceed to removing the object, after stopped the tractor, set the parking brake, stopped engine and removed the ignition key. Repair any damages immediately, and make sure rotor and blades are in good condition before restarting operation;
- avoid friction clutch overheating caused by too long or too frequent slipping of the clutch, since this can damage the friction plates and clutch parts.

Typical problems that may occur operating the tiller are described into Troubleshooting section, together with their solutions.

5.3. ADJUSTMENTS



WARNING

All adjustment operations must be performed with the tractor engine off, the PTO disengaged, the tiller lowered to the ground or on security stands, the parking brake set and the ignition key off.

LOWER HITCHES ADJUSTMENT

Both in the tiller configuration aimed to be connected to Category II tractors and to Category III, there is the possibility of having the lower hitches swinging during soil working.

To get the lower hitches swinging, simply remove the safety pins (1) and remove the pins (2) as shown in the figure. Carefully store the pins and cotter pins for possible later use.

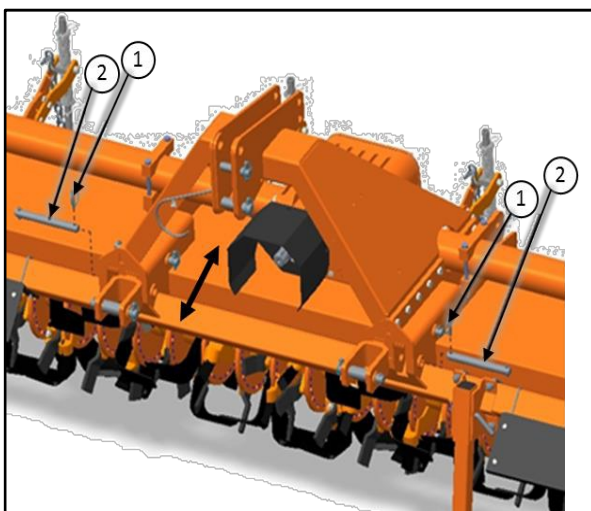

FRICION CLUTCH ADJUSTMENT

The PTO driveshaft and friction clutch are designed to transmit adequate power to the tiller.

The clutch preserves the machine from overloads, through the slipping of friction discs, and limits the max torque transmissible to a calibrated value set at factory. It is recommended, therefore, to leave unchanged this value to avoid damages to the machine or to driveshaft.

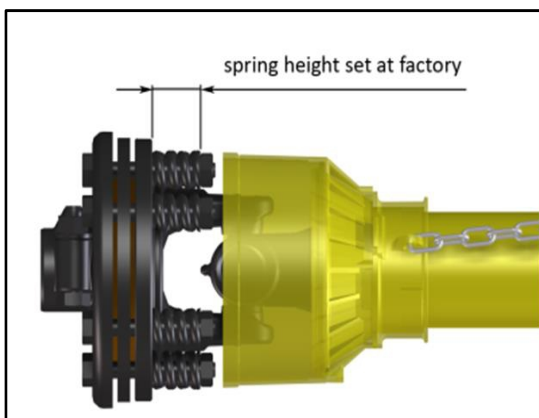

An adjustment can be done, however, when the clutch slipping is too frequent, which means that the calibration is too low.

In this case, the tightening of nuts over the compressed springs will give an increase in torque transmissible.

On the contrary, a loosening of the nuts over the springs will give a decrease in torque transmissible.

IMPORTANT

For details about clutch adjustment, refer to the user manual of the Manufacturer of the driveshaft installed.

The Manufacturer is not liable for damages resulting from a wrong modification of the clutch calibration.

NOTE

Excessive tightening of the springs can prevent the clutch from slipping and to protect the machine from overload.

Make sure that the height of all the compressed springs is equal to prevent clutch malfunctioning.

WORKING DEPTH ADJUSTMENT

Depending on the configuration of the tiller, the working depth can be set by the position of one of the two following devices:

- side skids, if the machine does NOT include a rear roller.
In this case, to change the working depth, follow the instructions listed in the section "Skid Adjustment";
- rear roller, if the machine is equipped with a roller.
In this case, to change the working depth, follow the instructions listed in the section "Rear roller adjustment."

SKIDS ADJUSTMENT

If the tiller doesn't include a rear roller, the working depth of the machine is determined by the position of the side skids: the depth can be increased by raising the skids and decreased by lowering the skids. Both skids must be always adjusted to the same height.

To adjust the working depth, perform the following steps:

- lift the machine, put it safely on security stands, wait until all rotation parts are completely stopped then switch the tractor engine off, disengage PTO, set parking brake and off the ignition key;
- loose bolts (1) and (2) (see picture below);
- loose the bolts (3);
- set the skid height as desired, shifting the indented plate (4);
- Tighten the bolts (3), (1) & (2). Refer to the tightening table of this manual for proper torque values.

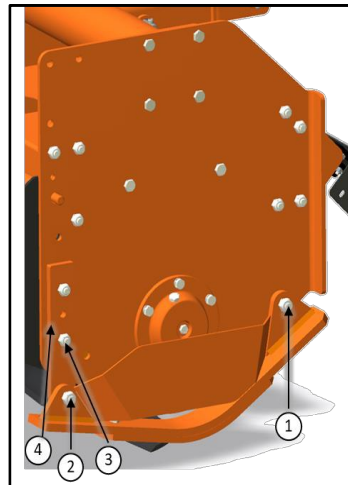

When finished, verify that both skids are at same level, and check if the front of the tiller is leveled to the back, when lowered to the ground. Adjust the level through the 3-point top link if necessary.

LEVELING BOARD ADJUSTMENT

The JUMBO tillers are equipped with one or two rear leveling boards (according to the size of the machine), which have the function of containing the soil during the working operation, and subsequent leveling of it.

The rear covers are bolted together in the central part of the tiller in order to make a single body, and are kept in position by spring adjusters connected to the frame.

Acting on the spring adjusters the operator can adjust the opening of the boards and get a more or less leveling effect on the ground. Function of the spring adjusters is also to damp the covers during the transport on the road, and avoid the tipping of the machine during parking.

To reduce the leveling effect on the soil it is required bring the covers in more open position, acting on the spring adjusters through the following steps:

- remove the cotter pin (2) from the tube of each adjuster, and place it in the hole immediately below;
- lift the cover;
- remove the cotter pin (1) from the tube of each adjuster, and place it in the hole immediately below.

To increase the leveling effect on the soil it is required bring the covers in less open position, acting on the spring adjusters in opposite way to described above.

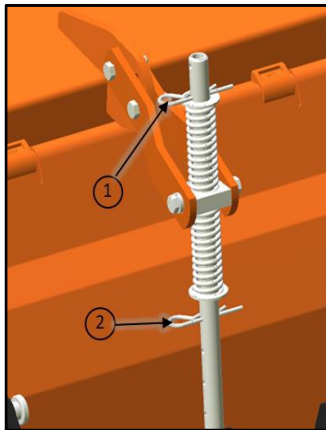

WARNING

To prevent the risk of crushing or shearing of the fingers, raise or lower the rear cover from the back edge only, not from the sides.

The rear covers are very heavy; perform the adjustment operations solely with the aid of support stands that prevent the sudden closure.

A further possibility to make the adjustment of the rear cover's adjustment is given by the presence on the tiller frame of several positioning holes designed to clamp the fixing elements of the spring adjusters.

By changing the position of the fixing elements (1) of the spring adjusters on the positioning holes of the tiller frame (2), it is possible raise or lower the leveling effect of the covers without acting on the spring adjusters (see picture below):

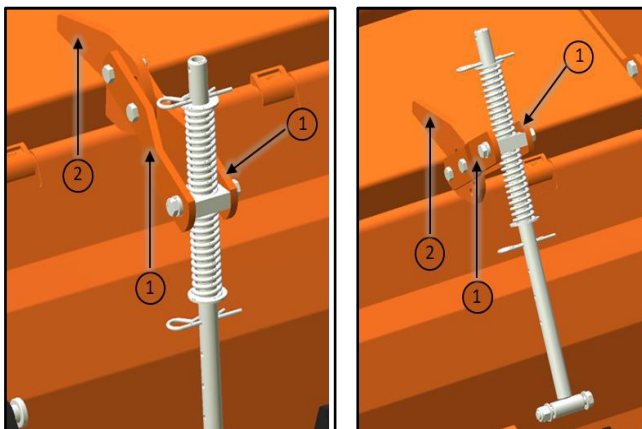

IMPORTANT

Make sure that all spring adjusters are set in the same way, so that the weight of the covers is equally divided between them.

For particular applications that require to operate with a very wide angle of the rear leveling boards (e.g.: with spike rollers), the tiller can be equipped with a special set of short boards, to use instead of the standard ones.

In this case, according to the angle required for the rear boards, and to the roller size, it is necessary to adjust the position of the roller from the tiller frame (v. Paragraph "Rear roller adjustment"), in order that there is no interference between the rear boards and the roller itself.

REAR ROLLER ADJUSTMENT

The function of the rear roller is to level and compact the soil, reducing the excessive softness subsequent to the process of working.

Depending on the characteristics of the soil and the desired result, the following types of rolls can be used:

- **Cage roller:** is suitable for soils with medium-low degree of humidity. It allows to control the working depth, level the tilled soil, and complete the refinement of the seedbed.
- **Spike roller:** is suitable for each type and condition of soil, in particular for soils with high degree of humidity. It does not compact the soil, but leaves it levelled and ventilated, providing excellent drainage. It is mainly used when is required a preparatory work on the ground already deeply worked.
- **Packer roller:** is suitable for any type and condition of soil. It is recommended for heavy soils and for soil preparation in combination with a seed drill. Allows to refine the surface of the seedbed, and has a great effect leveling and crumbling on the surface and in depth.

The roller is supported by a frame linked to the side plates of the tiller by means of two swinging arms.

The distance of the roller from the tiller frame can be adjusted in three different positions (max shift: 80 mm), in order to allow a more or less opening of the rear leveling boards. The position of the roller can be changed performing the following steps (see picture below):

- remove the bolts (1) clamping the frame to the swinging arm (2);
- increase or reduce the distance of the roller relative to the tiller, by sliding the frame along the arm, as desired;

- reconnect the frame to the swinging arm by replacing the two bolts, and tighten them according to the table in the manual (see. Section "Torque values table").

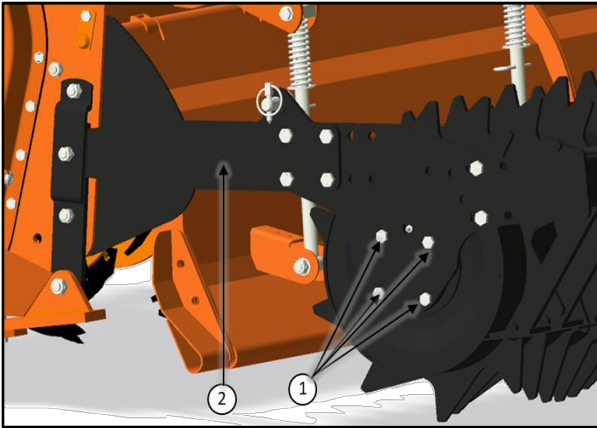

⚠ DANGER

Danger of crushing. The roller is very heavy, perform the adjustment operations solely with the aid of support stands that prevent the fall or the accidental overturning of the roller. In the presence of the rear roller the tiller is configured with fixed side skids. In this case the working depth is determined by the height of the roller, which can be adjusted by the operator:

- manually (in the case of roller with mechanical jacks or links), or
 - hydraulically (in the case of roller with hydraulic jacks),
- as described in the following paragraphs.

ADJUSTMENT THROUGH MECHANICAL JACKS

In the case the roller is equipped with mechanical jacks for lifting (see picture below), to adjust the height of the roller is necessary rotate the crank (1), until the desired height is reached.

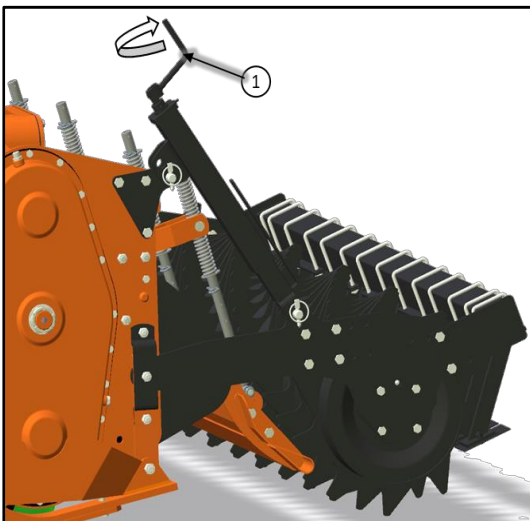

The lifting of the roller corresponds to an increase of the working depth of the machine, the lowering of the roller corresponds to a decrease of the working depth.

The position of the roller frame relating to the swinging arms affects the adjustment of the working depth.

 **WARNING**

Always make sure that the roller is positioned at the same height on both sides, through the suitable indicator of the jack.

ADJUSTMENT THROUGH HYDRAULIC JACKS

In case of configuration with roller and hydraulic cylinders, the height adjustment of the roller is affected by actuating the cylinders directly by the hydraulic control system of the tractor.

The lifting of the roller corresponds to an increase of the working depth of the machine; the lowering of the roller corresponds to a decrease of the working depth.

The position of the roller frame relating to the swinging arms affects the adjustment of the working depth.

LEVELING BAR ADJUSTMENT

The use of the blade rotor requires the presence of a rear leveling bar, adjustable in height through two lateral jacks, combined with special short rear boards.

The leveling bar, together with the rear boards, allows to retain the thickest clods in the working area of the rotor, ensuring the complete crumbling of the soil in aggregates of smaller size, and levels the ground better than how can be obtained with the use of standard leveling boards.

The configuration with blade rotor and leveling bar is suitable for seedbed preparation of land particularly tough or unplowed.

To adjust the height of the leveling bar it is necessary to turn the crank (1), until the desired height is reached (see figure).











 **WARNING**

Always make sure that the leveling bar is positioned at the same height on both sides, through the suitable indicator of the jack.

GEARBOX SPEED ADJUSTMENT

The central gearbox of the tiller is equipped with two pairs of interchangeable gears, (a default and a reserve pair). In function of the pair of gears selected and of the speed at the input shaft (540 or 1000 rpm), it is possible to obtain different speeds of rotation of the rotor, in order to meet different needs of the operators. Higher rotation speeds of the rotor correspond to a greater crushing of the ground.

The permitted combinations for the pairs of gears, with the relative speed of rotation of the rotor, are printed on a plate applied to the machine, as given below:

PTO SPEED				
540 RPM	Z-23		Z-17	248
	Z-21		Z-19	203
	Z-22		Z-18	224
1000 RPM	Z-15		Z-25	204
	Z-17		Z-23	251
	Z-18		Z-22	278

To change the speed, the operator must:

- remove the 4 screws (1) of the back cover of the gearbox;
- remove the gear (2) and (3) from the shafts, exchange their position, then replace them on the shafts. Alternatively, replace the pair of default gears (2) and (3) on the shafts with the gears (4) and (5) of the reserve pair, which are keyed on two pins of the back cover of the gearbox;
- retighten the four screws (1) of the back cover of the gearbox.

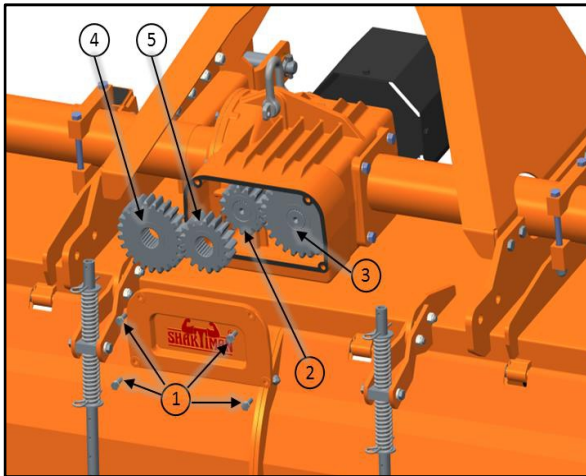

WARNING

Before perform a gearbox speed adjustment, make sure that the temperature of the gearbox is low enough to allow the necessary operations. Wear the required PPE, in particular the gloves, because of danger of burns.

Before opening the back cover of the gearbox, reduce the level of the oil to avoid spill out, following the instructions in the section "Gearbox lubrication".

The configurations permitted for the pair of gears and speeds are indicated in the table. The use of different configurations can seriously affect the functioning of the tiller, damaging it permanently.

Any adjustment on the gearbox must be done with the machine disconnected from the tractor or the tractor with the engine off and the machine on the ground.

5.4. STOPPING AND DISCONNECTION

To stop the tiller at the end of a working session:

- bring the tractor to a complete stop;
- place the transmission in park or neutral;
- reduce the engine speed, then disengage the PTO;
- wait for stopping of all rotating parts;
- lower the implement to the ground;
- set the parking brake;
- shut down the engine and remove the key before exiting the tractor;
- Do the cleaning and maintenance required to make the machine ready for later use (see section Maintenance).



WARNING

Never leave the tractor unattended with the implement in the lifted position.

To disconnect the tiller from the tractor (e.g. to make a change of implement):

- adjust the skids to their lowest position (see section Adjustments);
- adjust the parking stand to the lowest position, through the use of relative retaining pin;
- park the tractor on a dry and level surface;
- reduce the engine speed, then disengage PTO;
- wait for stopping of all rotating parts;
- lower the implement to the ground;
- set the parking brake;
- shut down the engine and remove the key before exiting the tractor;
- Place safety blocks under tiller to prevent unit from tipping over onto a child and/or an adult. A tiller that tips over can result in injury or death;
- disconnect the driveline from the tractor PTO and rest it on the provided support of the tiller;
- disconnect the top link and rear lifting arms of the tractor from the tiller hitches;
- Check the tiller stability. If needed, place additional safety blocks;
- get on the tractor, start the engine and move away from the tiller slowly;
- Make sure the tiller remains stored in a protected area, to prevent that unauthorized personnel can approach it.

Before a long-term storage (e.g. at seasonal end), do cleaning and maintenance operations as specified in sections MAINTENANCE and STORAGE.

5.5. TRANSPORTING

To set the tiller for transportation, perform the following steps:

- idle tractor engine, disengage tractor PTO, and wait for stopping of all rotating parts;
- lift the tiller until the transport position, making sure the driveline transmission tubes does not contact tractor or tiller. A minimum gap of 2 cm should be leaved between the tubes and tractor and tiller (see also section Driveline installation);
- lock the tractor lifting hydraulics, turn off the engine, set the parking brake, remove ignition key and get off the tractor;
- adjust the parking stand to the highest position, through the use of relative retaining pin, to prevent its possible damage during transport.

When driving on public roads, follow strictly all local laws and traffic regulations.



WARNING

When driving on public roads, reduce your speed, be aware of traffic around you and proceed in such a way that faster moving vehicles may pass you safely.

6. MAINTENANCE

Proper and regular maintenance ensures a long life of the equipment avoids failures and saves time and repair costs.

Periodic inspections and maintenance operations described in this section must be performed by operator in the times and terms prescribed. Failure to comply with maintenance prescriptions can compromise the functioning and duration of the machine, and consequently invalidate the warranty.

The frequency of maintenance indicated refers to normal conditions of use: it must be intensified in severe operating conditions (frequent stops and starts, prolonged winter season etc. ...).

Repairs, maintenance and modifications other than those mentioned in this paragraph should NOT be performed without consulting the Manufacturer or your Dealer. Manufacturer, as the case, may give the authorization to proceed with the repair together with all necessary instructions.

Wrong or inappropriate repairs or maintenance may generate abnormal operating conditions, equipment damage and generate risks for the operator.



WARNING

For safety reasons, all maintenance operations must be performed with tractor PTO disengaged, tiller stopped and completely lowered to the ground or onto support blocks, parking brake set, tractor engine shut off, and ignition key removed.

IMPORTANT

Respect the environment. Store or dispose of unused chemicals as specified by the chemical Manufacturer.

6.1. REPLACEMENT OF TOOLS

Frequently check the wear of the tools on the rotor through visual inspection. The wear of blades is variable depending on the type of soil.

Replacement of the tools is necessary when the operator notices increase of power absorption during tilling, or when the blade dimension is significantly reduced compared to the original.

Operate the machine with tools in bad condition compromises the quality of work.

Before perform the replacement of the tools:

- idle tractor engine, set the parking brake, disengage tractor PTO, and wait for all moving parts to come to a complete stop;
- place the tiller slightly raised off the ground on blocks or safety stands;
- lock the hydraulic lift of the tractor;
- Switch off the engine and remove the key from the control panel.

REPLACEMENT OF TINES (TINES ROTOR)

To perform the replacement of the tines on the rotor "A" and "B" type, after executed the steps above, it is necessary for each blade (see picture below):

- remove the nuts (1), washers (2) and screws (3), clamping the tine to the rotor flange;
- Remove the tine (4), position the new tine exactly instead of the worn tine, then tighten the bolts, referring to the tightening table of this manual for proper torque values. Be sure to install the tine with cutting edge in front of the direction of rotation;
- Repeat the same procedure for all the other tines.

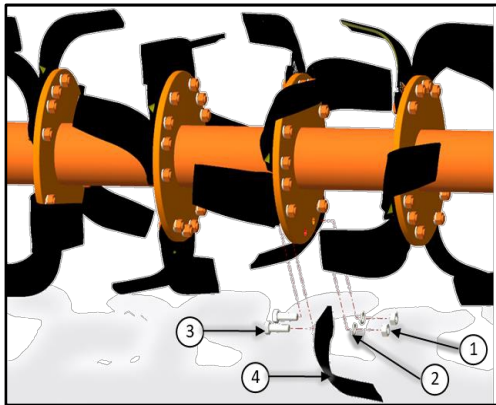

At the end of the replacement, make sure the tines have the right helical arrangement, as shown in the figure:

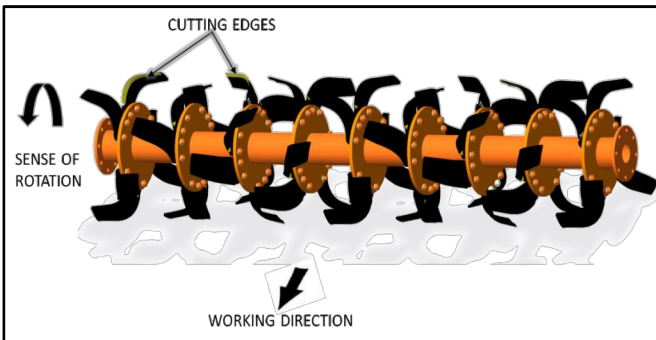

Periodically check the tightness of screws and nuts, and tighten if necessary.

IMPORTANT

Remove and install one tine at a time to ensure that tines are correctly oriented when installed.

Replace worn tines only with original parts.

⚠ CAUTION

Worn tines may be very sharp!

REPLACEMENT OF BLADES (BLADES ROTOR)

The use of the blade rotor (combined with the leveling bar) is suitable for seedbed preparation of land particularly tough or unplowed.

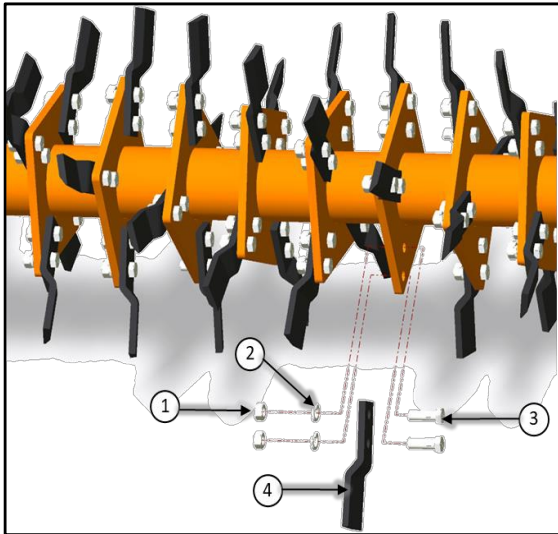

To perform the replacement of the blades on the blade's rotor, after executed the steps described at the beginning of this section, it is necessary for each blade (see picture above):

- remove the nut (1), washer (2) and screw (3), clamping the blade to the rotor flange;
- Remove the blade (4), position the new blade exactly instead of the worn blade, then tighten the bolts, referring to the tightening table of this manual for proper torque values. Be sure to install the blade with cutting edge in front of the direction of rotation;
- Repeat the same procedure for all the other blades.

Periodically check the tightness of screws and nuts, and tighten if necessary.

IMPORTANT

Replace worn blades only with original parts.

⚠ CAUTION

Worn blades may be very sharp!

REPLACEMENT OF SPIKES (SPIKES ROTOR)

The use of the spike rotor (combined with the leveling bar) is suitable for seedbed preparation on tough and stony soil.

To perform the replacement of the spikes on the spike's rotor, after executed the steps described at the beginning of this section, it is necessary for each spike (see picture below):

- remove the nut (1), washer (2) and screw (3), clamping the spike to the rotor flange;

- Remove the spike (4), position the new spike exactly instead of the worn spike, then tighten the bolts, referring to the tightening table of this manual for proper torque values. Be sure to install the blade with cutting edge in front of the direction of rotation;
- Repeat the same procedure for all the other spikes.

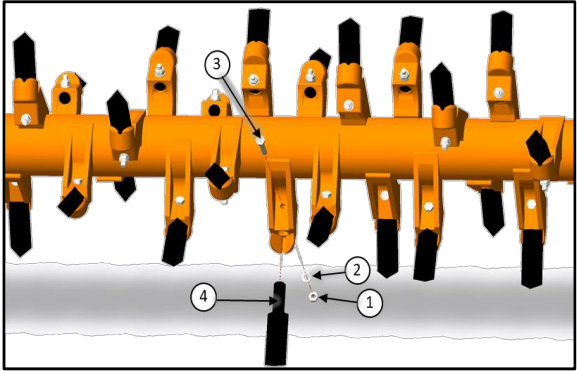

Periodically check the tightness of screws and nuts, and tighten if necessary.

IMPORTANT

Replace worn spikes only with original parts.



Worn spikes may be very sharp!

6.2. SCRAPER PLATES REPLACEMENT (PACKER ROLLER)

The packer roller is equipped with a rear bar supporting the scrapers, which have the function to clean the roller by the accumulation of the soil. The optimal distance between the roller and each scaper is 2-3 mm.

Frequently check the wear of the scraper blades, and provide for the replacement of the blades excessively worn, in order to assure a more efficient cleaning of the roller.

To perform the substitution of a blade (see picture below):

- unscrew the mounting bolts (1) and remove the blade (2);
- position the new blade on the support (3) through the bolts and tighten them only partially;
- Slide the blade on the support through the slots, until the desired distance from the roller is reached (distance suggested: 2-3 mm), then complete the tightening of the bolts. For the correct torque values Refer to the section "Torque values table".

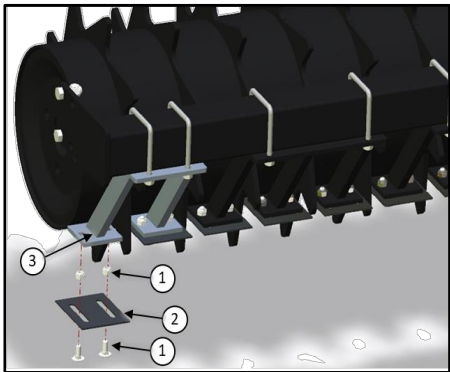

IMPORTANT

At the first use, or after replacement of the blades, it is suggested to adjust the blades after few minutes of machine working.

6.3. GEARBOX LUBRICATION

Lubricant: **HP 85W140 (API GL4)** gear oil

Check the oil level every 50 hours, making sure that the mark left from the oil on the dipstick of the filling plug (top of gearbox) is located between the two reference marks (minimum and maximum).

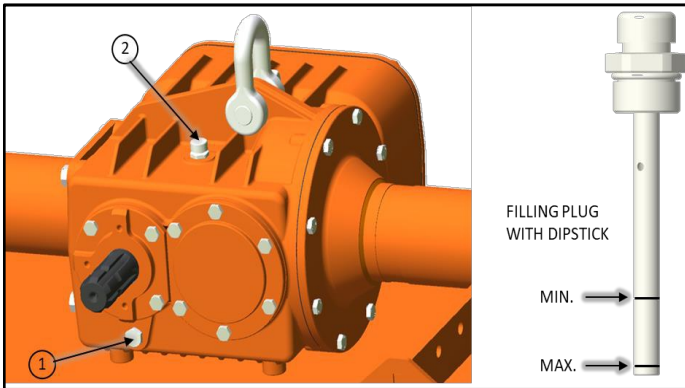

If the mark is below the minimum, fill up oil till restore the correct level.

The oil change must be performed:

- after the first 50 working hours;
- Each 500 working hours.

To make the oil change:

- place a tank under the oil drain plug (1) at bottom of gearbox;
- unscrew the oil drain plug and drain oil completely into the tank;
- retighten the drain plug;
- unscrew the oil filling plug (2);
- fill up oil till restoring the correct level (between the two reference marks on dipstick);
- retighten the filling plug;
- Dispose the discharged oil into containers for used oil.

**CAUTION**

Before touching the gearbox wait until it has cooled sufficiently.

IMPORTANT

Frequently check possible oil leaks from tiller through visual inspection, and in case of leakage provide immediately proper maintenance.

Avoid oil leaks on the ground when restoring oil level or making oil change.

6.4. SIDE CASE LUBRICATION

Lubricant: HP 85W140 (API GL4) gear oil.

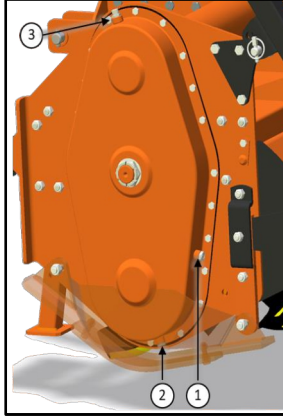

Check the oil level every 50 hours, making sure it reaches the level plug (1) of the side transmission cover. If the oil is below this level, fill up oil till restore the level.

The oil change must be performed every 500 working hours.

To make the oil change:

- remove the skid from the transmission side;
- place a tank under the oil drain plug (2);
- unscrew the oil drain plug and drain completely the oil into the tank;
- retighten the drain plug;
- unscrew the oil filling plug (3);
- fill up oil till restoring the correct level (until level plug);
- retighten the filling plug (3);
- replace the side skid;
- Dispose the discharged oil into containers for used oil.

6.5. ROTOR BLADES BEARING LUBRICATION

Lubricant: HP 85W140 (API GL4) gear oil.

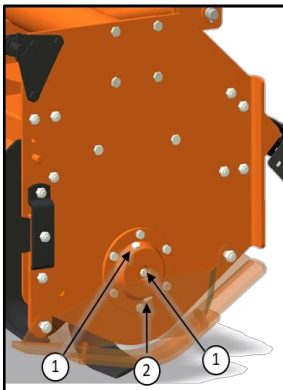

Check the oil level every 50 hours, making sure it reaches the level plug (1).

If the oil is below this level, fill up oil till restore the level.

The oil change must be performed every 500 working hours.

To make the oil change:

- remove the skid from the transmission side;
- place a tank under the oil drain plug (2);
- unscrew the oil drain plug and drain completely the oil into the tank;
- retighten the drain plug;
- unscrew the oil filling plug (3);
- fill up oil till restoring the correct level (until level plug);
- retighten the filling plug (3);
- replace the side skid;
- dispose the discharged oil into containers for used oil.

6.6. REAR ROLLER BEARING LUBRICATION

Lubricant: AGIP GREASE MU EP 2 lithium-type grease (or equivalent).

The rear roller's bearing housing are built with pre-lubricated sealed bearings. Exposure to water or dust, however, require an occasional re lubrication with high quality grease.

It is suggested to grease the bearings every 50 hours, till to observe the first oozing fat from the outer ring of the bearing, in order to prevent overfilling.

The greasing point is shown in the figure below.

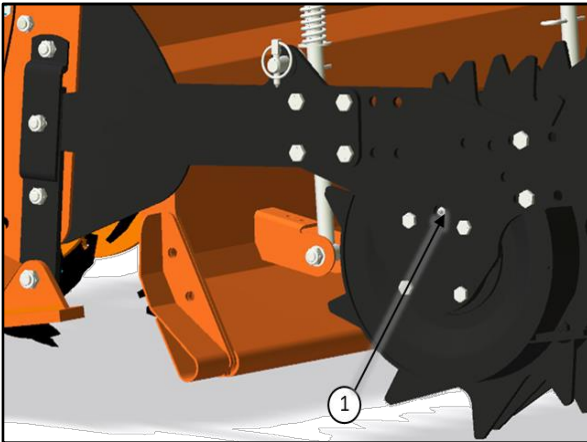

IMPORTANT

Make sure to clean the fitting zerk before using the grease gun.

Do not let excess grease collect on or around parts, particularly when operating in sandy areas.

6.7. MECHANICAL JACK LUBRICATION

Lubricant: AGIP GREASE MU EP 2 lithium-type grease (or equivalent).

The mechanical jacks designed to lift the rear roller must be greased every 50 hours through the nipple (1) positioned next the crank. The greasing point is shown in the figure below:

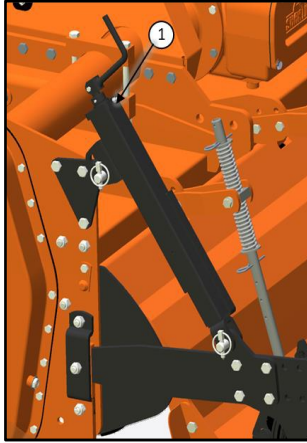

IMPORTANT

Make sure to clean the fitting zerk before using the grease gun.

Do not let excess grease collect on or around parts, particularly when operating in sandy areas.

6.8. DRIVESHAFT MAINTENANCE

Lubricant: SAE multi-purpose lithium-type grease

Grease crosses, sliding parts of protective shielding and driveshaft transmission tubes.

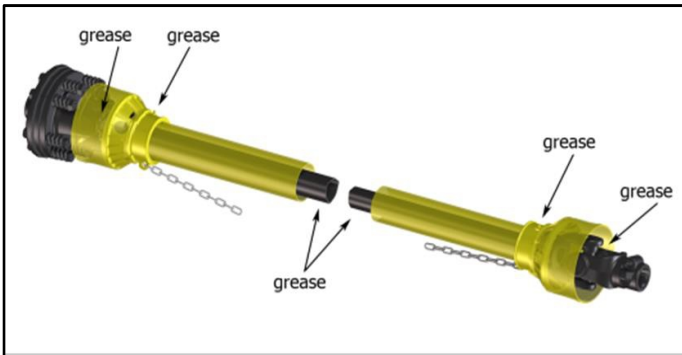

IMPORTANT

For details about maintenance and lubrication of the driveshaft, refer to the user manual of the driveshaft Manufacturer.

Driveshaft clutch:

Exposition to the elements of tiller and driveshaft, or a long period of inactivity, generally results in oxidation of some clutch components, and creates "sticking" effect on the clutch.

Consequently, the torque required to the slippage of the clutch increases considerable respect to the value set at factory, and this may be cause of driveshaft breakage during operation, or damage to the tractor or implement.

To avoid it, before re-using the tiller, operator must perform a short "run-in" of the clutch, as follows:

- take note of the height of the compressed springs;
- loosen the bolts that compress the springs;
- connect the tiller to the tractor (see section Connecting to the tractor);
- connect the driveshaft (see section Driveline installation);
- start the tractor and engage PTO for few seconds, in order to cause slippage and separation of the parts "sticked" of the clutch;
- turn off the tractor, remove key and wait for all components are stopped before dismounting from tractor;
- Retighten the bolts restoring the original spring's position on the driveshaft.

NOTE

For replacement of the driveshaft service parts (e.g. friction discs), refer to the user manual of the driveshaft Manufacturer.

7. STORAGE

Before leaving the tiller unused for a long time, it's necessary to perform following tasks to preserve the appearance and functionality of the machine, and to make easier the restart at later use:

- park the tiller on a flat surface, in a place dry and protected from exposition to the elements, possibly with storage temperature between 0 and 50 °C (see section Stopping and disconnection);
- thoroughly clean the machine, removing from the rotor all residues due to tillage, in order to avoid damage from grass and stagnant water;
- inspect carefully the machine, checking for worn and/or damaged parts. Perform immediately all repairs and/or replacements needed, in order to make the machine ready for restarting;
- in case of abrasion of painted surfaces, provide restoring the surface protection through touch-up paint to prevent rust;
- make sure the safety decals are in their original positions, intact and legible. When required, replace the decals immediately;
- lubricate properly all grease points, and restore the oil levels as indicated in the Maintenance section. Use protective oil to coat the exposed mechanical components and to protect them against rust.

If the tiller driveshaft is equipped with a friction clutch, it is suggested to take note of the height of the compressed springs and loosen the bolts that compress the springs, to prevent the discs from "sticking" effect due to moisture, that may cause the clutch failure at restart of the activities (see also Driveshaft maintenance).

Before restart the operations, restore the original height of the springs.

8. SCRAPPING

In case of scrapping, the machine must be disposed in appropriate and authorized sites, according to local legislation of the Country where the machine is used.

Before scrapping, separate plastic parts from rubber parts, aluminum, steel, etc.

Recover and dispose any exhausted oils to authorized centers for oil collecting.

9. TROUBLESHOOTING

PROBLEM	POSSIBLE CAUSE	POSSIBLE SOLUTION
<ul style="list-style-type: none"> • Gearbox/transmission case noise noticeable and constant 	<ul style="list-style-type: none"> • Low oil level. • Worn gears. 	<ul style="list-style-type: none"> • Add oil to the gearbox/transmission case. • Replace gears
<ul style="list-style-type: none"> • Intermittent • noise from tiller 	<ul style="list-style-type: none"> • Loose blades. • Gear tooth damaged. 	<ul style="list-style-type: none"> • Tighten blades hardware • Replace damaged gear
<ul style="list-style-type: none"> • Noise and/or vibration from tiller 	<ul style="list-style-type: none"> • Blades worn or damaged. • Bearings damaged. • The front of the tiller is not leveled to the back. • Rotor damaged. • Hard soil. 	<ul style="list-style-type: none"> • Replace blades. • Replace bearings. • Adjust 3-point top link of tractor making tiller PTO parallel to the ground. • Repair/replace rotor • Reduce ground speed
<ul style="list-style-type: none"> • Driveline vibration 	<ul style="list-style-type: none"> • Worn driveshaft. • Machine lifted too high. • Debris wrapped on rotor. 	<ul style="list-style-type: none"> • Replace driveshaft. • Lower machine and readjust tractor lift stop. • Remove debris.
<ul style="list-style-type: none"> • Rotor stops turning 	<ul style="list-style-type: none"> • Slip clutch slipping. • Broken chain in chain box. 	<ul style="list-style-type: none"> • Reduce load to tiller or adjust slip clutch. • Repair broken link.
<ul style="list-style-type: none"> • Machine skip or leaves • crop residue 	<ul style="list-style-type: none"> • Badly worn blades. • Slip clutch slipping. • Ground speed too fast for conditions. 	<ul style="list-style-type: none"> • Replace worn blades. • Adjust slip clutch or reduce load. • Reduce ground speed.
<ul style="list-style-type: none"> • Smoke and/or hot smell from tiller 	<ul style="list-style-type: none"> • Debris wrapped around in blades and/or rotor. • Low oil level in gearbox. • Slip clutch slipping. 	<ul style="list-style-type: none"> • Remove debris. • Add oil • Reduce load to machine or adjust slip clutch.
<ul style="list-style-type: none"> • Gearbox overheating 	<ul style="list-style-type: none"> • Low oil level. • Hard soil. 	<ul style="list-style-type: none"> • Add oil. • Reduce ground speed.
<ul style="list-style-type: none"> • Blades wear frequently 	<ul style="list-style-type: none"> • Muddy or sandy soil. 	<ul style="list-style-type: none"> • Reduce ground speed.
<ul style="list-style-type: none"> • Blades break frequently 	<ul style="list-style-type: none"> • Stony soil. 	<ul style="list-style-type: none"> • Reduce ground speed.
<ul style="list-style-type: none"> • Oil leaking from gearbox/transmission case 	<ul style="list-style-type: none"> • Gearbox/transmission case overfilled. • Loose filling/drain plug. • Damaged breather plug. • Damaged seals. 	<ul style="list-style-type: none"> • Drain to proper level. • Tighten filling/drain plug. • Replace breather plug. • Replace seals.
<ul style="list-style-type: none"> • Tillage depth insufficient 	<ul style="list-style-type: none"> • Tiller is carried by tractor. • Tractor has insufficient power. • Skids need adjusting. • Blades worn or bent. • Blades incorrectly installed. • Debris entangled in blades and/or rotor. 	<ul style="list-style-type: none"> • Lower tractor 3-point arms. • Increase PTO speed • Adjust skids. • Replace blades. • Install tines correctly. • Clear rotor and/or blades
<ul style="list-style-type: none"> • Soil texture too coarse 	<ul style="list-style-type: none"> • Rear board too high. 	<ul style="list-style-type: none"> • Lower rear board.

	<ul style="list-style-type: none"> • PTO speed too slow. • Ground speed too fast. 	<ul style="list-style-type: none"> • Increase PTO speed. • Reduce ground speed.
<ul style="list-style-type: none"> • Soil texture too fine 	<ul style="list-style-type: none"> • Rear board too low. • Ground speed too slow. 	<ul style="list-style-type: none"> • Raise rear board • Increase ground speed.
<ul style="list-style-type: none"> • Tiller choking up with soil 	<ul style="list-style-type: none"> • Blades worn or bent. • Blades incorrectly installed. • Rear board too low. • Soil too wet. 	<ul style="list-style-type: none"> • Replace blades. • Install tines correctly. • Raise rear board. • Wait until soil dries.
<ul style="list-style-type: none"> • Tiller skipping on ground or leaving crop residue 	<ul style="list-style-type: none"> • Blades incorrectly installed (wrong helical arrangement, cutting edge in wrong direction...) • Debris entangled in blades and/or rotor. • Ground speed too fast. • Soil too hard. 	<ul style="list-style-type: none"> • Install blades correctly (replace right helical arrangement, position cutting edge in front of rotation direction...) • Clear rotor and/or blades. • Reduce ground speed. • Reduce ground speed and make tilling in more steps.
<ul style="list-style-type: none"> • Tillage not uniform • 	<ul style="list-style-type: none"> • Blades worn or damaged. • Skids not aligned. • Tiller left side not leveled with right side. 	<ul style="list-style-type: none"> • Replace blades. • Align skids. • Adjust tractor 3-point arms. • Adjust roller.
<ul style="list-style-type: none"> • Too load required to tractor 	<ul style="list-style-type: none"> • Excessive working depth. • Excessive PTO speed. 	<ul style="list-style-type: none"> • Lower skids. • Lower roller. • Reduce PTO speed.

10. TORQUE VALUES TABLE

Check frequently tiller hardware to make sure that screws and bolts are tightened according to torque values listed in following table:

BOLT SIZE (METRIC)	8.8 GRADE	10.9 GRADE	12.9 GRADE
	Nm	Nm	Nm
M6	11	15	15
M8	26	36	40
M10	52	72	81
M12	91	125	143
M14	145	200	218
M16	225	315	357
M18	310	405	478
M20	440	610	701

11. WARRANTY

M/s. Tirth Agro Technology Pvt. Ltd. offer the following warranty to the purchaser of Sundown equipment mentioned herein above subject to the conditions set out herein after provided the Sundown equipment shall be in the possession of and used by such purchaser from the date of delivery.

M/s. Tirth Agro Technology Pvt. Ltd. Warrants its products for a period of twelve (12) months from date of delivery, for manufacturing or material defects only. Failed part will be replaced at its authorized dealers only and any part component there of that shall be examined by them, shall disclose if to be defective. This warranty shall not apply to equipment or parts that have been subject to negligence, or accident, or not maintained as per company instructions specified in operator manual or that have been altered or repaired or used with non-genuine parts or abused or due to contaminated oil or used in not recommended application.

Warranty Terms & Conditions:

- 1) The purchaser of Sundown equipment should strictly follow the instruction given in the instruction manual provided by the company along with the Sundown equipment at the time of delivery. Changes if any, resulting in improper usage will not be covered by the warranty. This warranty will automatically terminate on the expiry of warranty period of Six months even the Sundown equipment may not be in use for any time during the warranty period for any reason whatsoever including any technical reasons and time taken for such repairs/replacement of parts, and in transit, whether under this warranty or otherwise shall not be excluded from the warranty period.
- 2) All wear and tear items like bearings, chains, sprockets, oil seals, tines, blades, rubber parts and gaskets are not covered under warranty.
- 3) All items with normal wear or failure due to normal wear will not be covered under warranty.
- 4) While the company or authorized dealers will make every effort to carry out repairs/replacement of parts under this warranty as soon as possible. It is expressly made clear that the company shall not be liable to do within any specific period of time.

In the event of repairs/replacement of any parts, this warranty will thereafter continue to remain in force only for the unexpired period of warranty.

- 5) It is entirely left to company discretion to repair/replacement of parts at the site of delivery or at the authorized service points of its dealers. The defective parts which has/have been agreed to be replaced, should be returned to the company without any further claim.
- 6) The warranty shall not cover any consequential or resulting liability, damage or loss arising directly or indirectly out of any defect in the Sundown equipment. This warranty shall be strictly limited to repairs and replacement of the defective parts specified in the warranty, and does not cover any reimbursement of labour charges for any repairs so earned out at dealer/client end.
- 7) This warranty shall not be extended in any case of replacement or return of the Sundown equipment as a whole. Only failed parts will be covered under warranty.
- 8) The purchasers of Sundown equipment will itself fully responsible for model/variant selection.
- 9) This warranty does not cover for statutory duties and taxes like excise, service tax or CST or VAT or State sales tax and octroi and any other local taxes payable on any of the parts which the company may supply or repairs free of cost during the warranty period.
- 10) This warranty also does not cover the cost of packaging, to and for freight and transportation charges etc., on the defective Sundown equipment or other parts of the Sundown equipment sent to company's works in Rajkot or to the authorized service station.

11) **Warranty becomes void if:**

- a) The Sundown equipment has not been delivered, assembled, started and put into operation by the company or its authorized representative.
 - b) The dully filled delivery certificate is not in our possession within 15 days from the date of delivery.
 - c) The Sundown equipment or any parts thereof is subjected to neglect, fire, floods or other acts of God or if in the company's opinion any damage has caused to the Sundown equipment during transportation.
 - d) The original serial number is removed, obliterated or altered from the unit.
 - e) Any attempt is made to have the repairs executed by a person or persons, other than the company or its authorized representative.
 - f) Any defect is not informed immediately to the company or its authorized representative, any alteration in warranty card is made.
 - g) Whenever the user or anyone else on his behalf applies equipment to the tractor or to prime mover that has not been expressly approved by the manufacturer or not suitable to the equipment.
- 12) a) Any changes in the location of the Sundown equipment or in the/its ownership thereof during the warranty period must be intimated in writing to the company or its authorized dealer within ten days before the change. Failure to do so will absolve the company from the obligation under this warranty.
- b) Further, in the case of shifting for the continuation of the Warranty, the Sundown equipment has to be inspected by the company or its authorized representative before shifting from the original location and before using it at the new location. The inspection free levied by the company or its authorized representative as well as the cost of rectification of any damage in transit, detected in the above inspection, shall be borne by the purchaser/owner, if at the time of restarting, the Sundown equipment is found to be in working order, this warranty shall continue to be in force for the remaining period of the warranty.
 - c) Damage to the Sundown equipment or any part thereof caused during shifting or transportation is not covered by this warranty.
- 13) None of the company representative or authorized dealer is authorized to alter/amend any terms and conditions of this warranty policy. Only the management of the company is authorized to do so. The decision of the company will be final and binding to the purchaser.
- 14) This warranty policy shall be governed by and construed in accordance with the laws of India and the courts in Rajkot shall have exclusive jurisdiction.
- 15) This warranty is given in lieu of all other guarantees and condition expressed or implied by law or by the any person purporting to act on behalf of the company and excludes every condition, warranty or guarantee not herein expressly set out.

Note: The parts/material that are not covered by this warranty are as follows:

1. Blades
2. Universal joint cross
3. Paint
4. Bearings
5. Rubber parts
6. Gaskets
7. Fasteners
8. Fabrication
9. Chains & sprockets
10. Tines

12. SPARE PARTS

All repairs and replacements on the machine must be performed only by using original spare parts, which must be obtained from the Manufacturer or your Dealer.

This section contains the information needed to identify the parts of U-series tillers that may be ordered to Manufacturer.

When request spare parts to Manufacturer, always give following indications:

- type of machine;
- tiller serial number;
- description and p/number of the spare parts;
- quantities.

NOTE

For identification of p/numbers and description of safety decals refer to the Section Safety labels.

For identification of p/numbers and description of PTO driveline parts, refer to the manual of the driveshaft Manufacturer.

The Manufacturer reserves the right to substitute a required part with an equivalent part, if applicable.

13. "EC" DECLARATION OF CONFORMITY

In accordance with the EC Machinery Directive 2006/42/EC

The company

Tirth Agro Technology Pvt. Ltd.

(An ISO 9001:2015 Certified Company)

National Highway – 27, Nr. Bharudi Toll Plaza,
Gondal Road At.: Bhunava – 360311 Ta. Gondal,

Dist.: Rajkot. State: Gujarat- INDIA.

Phone: + 91 (2827) 661637

e-mail: info@shaktimanagro.com

hereby declares that the machine:

Type: SUNDOWN Rotary Tiller

Model: Jumbo-Series

Satisfies the basic safety and health requirements established by European Directive 2006/42/EC.

Harmonized standards used:

EN ISO 12100:2010

Safety of machinery - General principles for design - Risk assessment and risk reduction

EN ISO 4254-1:2009

Agricultural machinery - Safety - Part 1: General requirements

EN ISO 4254-5:2009

Agricultural machinery - Safety - Part 5: Power-driven soil-working machines

EN ISO 13857:2008

Safety of machinery - Safety distances to prevent hazard zones being reached by upper and lower limbs

Other technical standard used:

ISO 11684:1995

Tractors, machinery for agriculture and forestry, powered lawn and garden equipment - Safety signs and hazard pictorials - General principles

Rajkot,
Ashwin Gohil / Hasmukh Gohil
Chairman / Managing Director



PART'S MANUAL

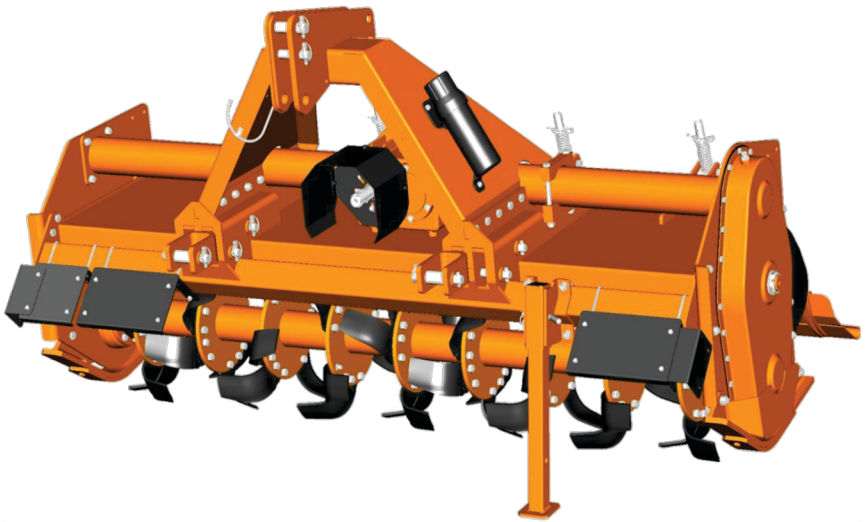

ROTARY TILLER JUMBO SERIES

INDEX



Page No.	Description	Revision Date
1.1	ACCESSORIES PARTS	PM1125-21EN-000_REV_005_DEC_20
1.2	ACCESSORIES PARTS	PM1125-21EN-000_REV_005_DEC_20
2.1	MACHINE PARTS	PM1125-21EN-000_REV_005_DEC_20
2.2	MACHINE PARTS	PM1125-21EN-000_REV_005_DEC_20
3.1	GEAR BOX ASSEMBLY PARTS	PM1125-21EN-000_REV_005_DEC_20
3.2	GEAR BOX ASSEMBLY PARTS	PM1125-21EN-000_REV_005_DEC_20
4.1	END PLATE ASSEMBLY TRASMISSION SIDE	PM1125-21EN-000_REV_005_DEC_20
4.2	END PLATE ASSEMBLY TRASMISSION SIDE	PM1125-21EN-000_REV_005_DEC_20
5.1	END PLATE ASSEMBLY EXTERNAL SIDE	PM1125-21EN-000_REV_005_DEC_20
5.2	END PLATE ASSEMBLY EXTERNAL SIDE	PM1125-21EN-000_REV_005_DEC_20
6.1	ROTOR PARTS	PM1125-21EN-000_REV_005_DEC_20
6.2	ROTOR PARTS	PM1125-21EN-000_REV_005_DEC_20
7.1	ROLLER PARTS	PM1125-21EN-000_REV_005_DEC_20
7.2	ROLLER PARTS	PM1125-21EN-000_REV_005_DEC_20
8.1	HYDRAULIC JACK, MECHANICAL JACK AND LEVELING BAR ASSEMBLY	PM1125-21EN-000_REV_005_DEC_20
8.2	HYDRAULIC JACK, MECHANICAL JACK AND LEVELING BAR ASSEMBLY	PM1125-21EN-000_REV_005_DEC_20
9.1	CE KIT AND SHORT REAR BOARD ASSEMBLY	PM1125-21EN-000_REV_005_DEC_20
9.2	CE KIT AND SHORT REAR BOARD ASSEMBLY	PM1125-21EN-000_REV_005_DEC_20

ACCESSORIES PARTS

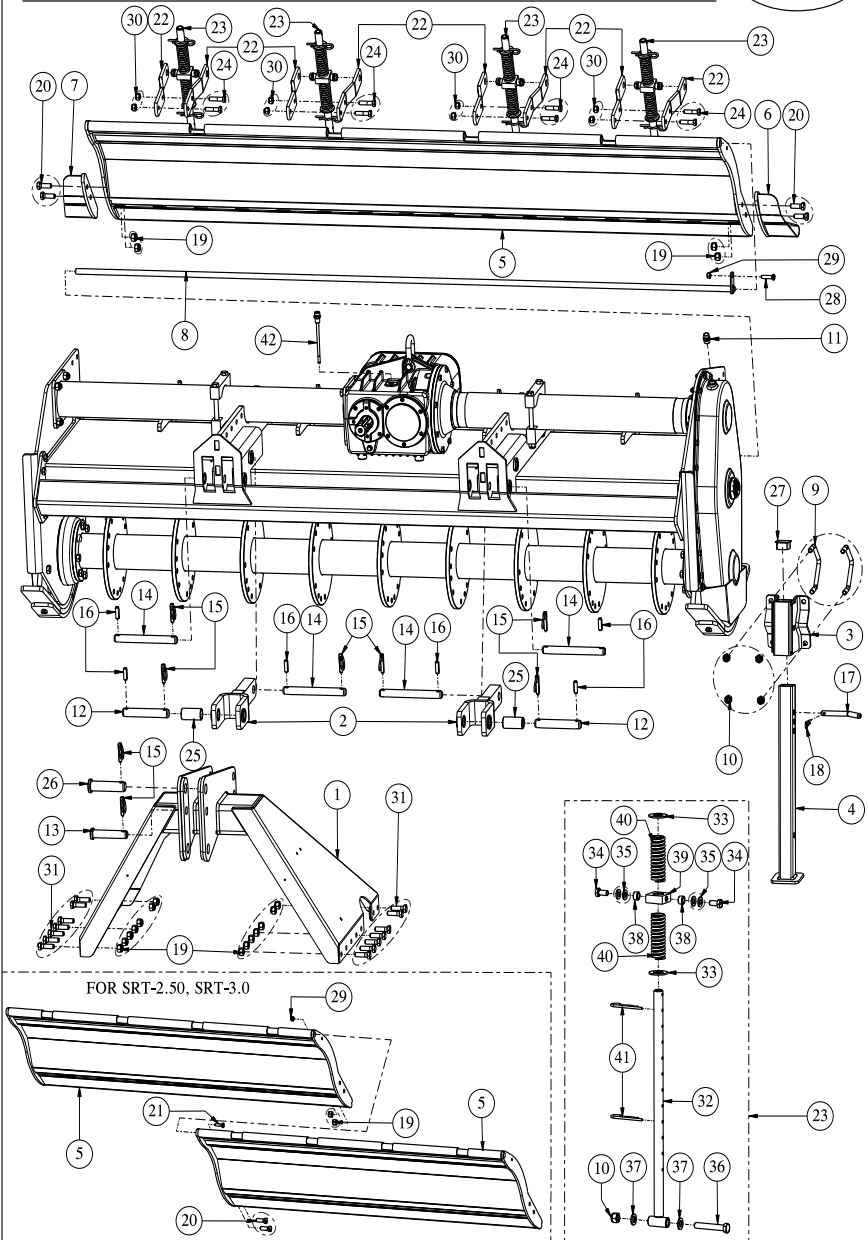

PM1125-21EN-000_REV_005_DEC_20

1.1

ACCESSORIES PARTS



Sr. No.	Part No.	Description	Qty.
1	23077	TOP MAST WELDMENT	1
2	23083	CLEVIS, LOWER HITCH (CATEGORY II)	2
3	23085	PARKING STAND MOUNT	1
4	23084	PARKING STAND	1
5	23179	REAR BOARD 200	1
	23289	REAR BOARD 250	
	23229	REAR BOARD 300	2
6	23079	EXTENSION, REAR BOARD -TR. SIDE	1
7	23080	EXTENSION, REAR BOARD-EX. SIDE	1
8	23425	ROD, REAR BOARD WELD. 200	1
	23292	ROD, REAR BOARD WELD. 250	
	23232	ROD, REAR BOARD WELD. 300	2
9	23495	V-BOLT M14X2140X125X30TL (8.8)	2
10	1574	NYLOCK NUT M14X2.00 (DIN-982)	5
11	14310	AIR BREATHER 1/2" BSP (1GTSR38)	1
12	23103	PIN, LOWER HITCH (CATEGORY II)	2
13	23104	PIN, TOP HITCH (CATEGORY II)	1
14	23105	PIN, LOWER HITCH ATTACHMENT	4
15	23062	LINCH PIN (D10XL45)	8
16	23067	SPRING PIN D12X40	6
17	23031	LOCKING PIN BIG	1
18	15055	R-CLIP WIRE DIA 4.00MM	1
19	1302	NYLOCK NUT M14X1.50 (DIN-982) (FOR SRT-2.0)	4
		NYLOCK NUT M14X1.50 (DIN-982) (FOR SRT-2.50, SRT-3.0)	6
20	23318	HEX BOLT M14 X 1.50 X 40 (8.8) DIN931 (FOR SRT-2.0)	4
		HEX BOLT M14 X 1.50 X 40 (8.8) DIN931 (FOR SRT-2.50, SRT-3.0)	6
21	3345	HEX BOLT M10 X 1.50 X 35 (8.8) DIN931 (FOR SRT-2.50, SRT-3.0)	1
22	23144	BRACKET, SPRING ADJUSTER SUPPORT	8
23	23145	SPRING ADJUSTER ASSEMBLY	4
24	23317	HEX BOLT M12X1.75X50(DIN931)(8.8)(ZP)	8
25	23154	BUSHING CAT-III ADAPTER	2
26	23155	PIN, TOP HITCH (CATEGORY III)	1
27	23163	SQ. PIPE PLASTIC CAP 50MM	1
28	6602	HEX BOLT M10 X 1.50 X 40 DIN 933 - 8.8 (FOR SRT-2.0)	1
		HEX BOLT M10 X 1.50 X 40 DIN 933 - 8.8 (FOR SRT-2.50, SRT-3.0)	2
29	1298	NYLOCK NUT M10X1.50 (DIN-982) (FOR SRT-2.0)	1
		NYLOCK NUT M10X1.50 (DIN-982) (FOR SRT-2.50, SRT-3.0)	3
30	1209	NYLOCK NUT M12X1.75 (DIN-982)	8
31	3339	HEX BOLT M14X1.50X45(DIN931)(8.8)(ZP)	14
32	23088	TUBE WELDMENT, SPRING ADJUSTER	1
33	23141	WASHER DIA 50 X 27 X 3	2
34	17474	HEX BOLT M12X1.75X25(DIN933)(8.8)(ZP)	2
35	8126	PLAIN WASHER 12MM (BS-4320)	4
36	23069	HEX BOLT M14X2.00X90(DIN931)(8.8)(ZP)	1
37	1272	PLAIN WASHER 14MM (BS-4320)	2
38	23142	SPACER, SPRING ADJUSTER	2
39	23143	BLOCK, SPRING ADJUSTER	1
40	23070	SPRING, REAR BOARD ADJUSTER	2
41	23068	R-CLIP D5 X L100 MM	2

MACHINE PARTS

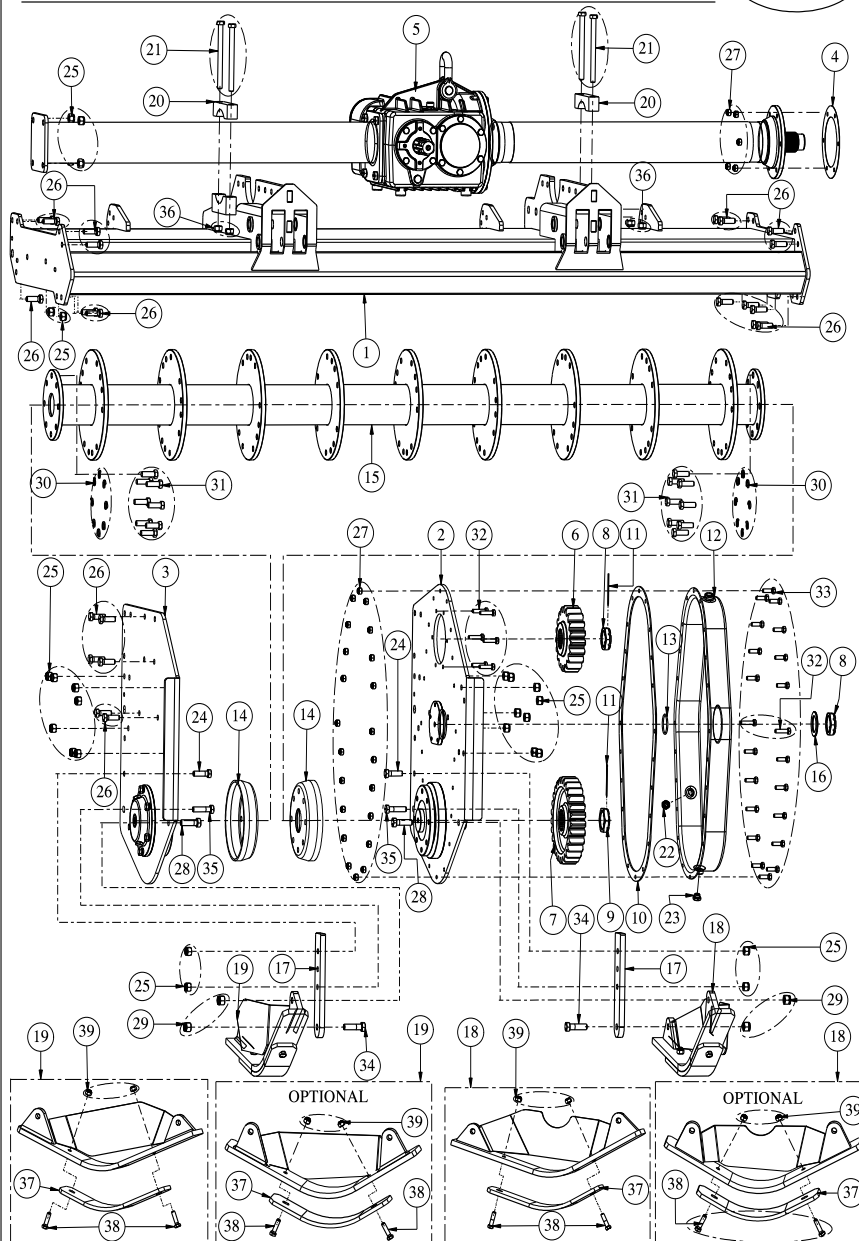

PM1125-21EN-000_REV_005_DEC_20

2.1

MACHINE PARTS



Sr. No.	Part No.	Description	Qty.
1	23172	FRAME WELDMENT 200 (JUMBO)	1
	23288	FRAME WELDMENT 250(JUMBO)	
	23228	FRAME WELDMENT 300(JUMBO)	
2	-	TR. SIDE ASSEMBLY (SEE TRASMISSION SIDE ASSEMBLY PAGE)	1
3	-	EX. SIDE ASSEMBLY (SEE EXTERNAL SIDE ASSEMBLY PAGE)	1
4	23061	GASKET.SHAFT BEARING MOU.TR 0.5 NA	1
5	-	GEAR BOX (SEE GEAR BOX ASSEMBLY PAGE)	1
6	23032	GEAR, DRIVING Z-19	1
7	23039	GEAR, DRIVEN Z-27	1
8	23431	CASTLE NUT M45X1.5, L=16.5	2
9	2595	CASTLE NUT 50mm	1
10	23009	GASKET SIDE DRIVE COVER	1
11	1571	COTTER PIN (DIA 3.5 X 80)	2
12	23075	COVER WELDMENT, GEAR SIDE DRIVE	1
13	20351	O" RING ID-47.2 MM X W-3.5 MM	1
14	23042	COVER, DIRT PROTECTION	2
15	-	ROTOR WELDMENT (SEE ROTOR PAGE)	1
16	23059	PLAIN WASHER 45 X 70 X 3.00	1
17	23385	SKID ADJUSTMENT	2
18	23164	SKID WELDMENT TRASMISSION SIDE	1
	23113	SKID WELDMENT (FIXED), TR. SIDE (OPTIONAL-ONLY FOR ROLLER)	
19	23165	SKID WELDMENT, EXTERNAL SIDE	1
	23114	SKID WELDMENT (FIXED), EX. SIDE (OPTIONAL- ONLY FOR ROLLER)	
20	23102	BRACKET, TUBE CLAMPING - UPPER	2
21	23063	HEX BOLT M14X2.00X180(DIN931)(8.8)(ZP)	4
22	14314	OIL LEVEL GAUGE-3/8" BSP (1GTLA210)	1
23	14312	DRAIN CAP 3/8" BSP (1GTC02UW)	1
24	3339	HEX BOLT M14X1.50X45(DIN931)(8.8)(ZP)	2
25	1302	NYLOCK NUT M14X1.50 (DIN-982)	26
26	23318	HEX BOLT M14X1.50X40(DIN931)(8.8)(ZP)	22
27	1298	NYLOCK NUT M10X1.50 (DIN-982)	26
28	7108	HEX BOLT M16X2.00X50(IS1364-1)(8.8)(ZP)	2
29	1231	NYLOCK NUT M16X2.0 (DIN-982)	4
30	14363	SPRING WASHER M14.00(IS 3063)(ZP)	16
31	23064	HEX BOLT M14X2.00X40(DIN933)(8.8)(ZP)	16
32	3342	HEX BOLT M10X1.50X40(DIN931)(8.8)(ZP)	8
33	3340	HEX BOLT M10X1.50X30(DIN933)(8.8)(ZP)	20
34	18446	HEX BOLT M16X2.00X55(IS1364-1)(8.8)(ZP)	2
35	23384	HEX BOLT M14X1.50X55(DIN931)(8.8)(ZP)	2
36	1574	NYLOCK NUT M14X2.00 (DIN-982)	4
37	23440	SKID, PROTECTION PLATE BOTTOM	2
	23442	SKID,PROTECTION PLATE BOTTOM FIX (OPTIONAL-ONLY FOR ROLLER)	
38	3338	HEX BOLT M12X1.75X45(DIN931)(8.8)(ZP)	4
39	1209	NYLOCK NUT M12X1.75 (DIN-982)	4

GEAR BOX ASSEMBLY PARTS

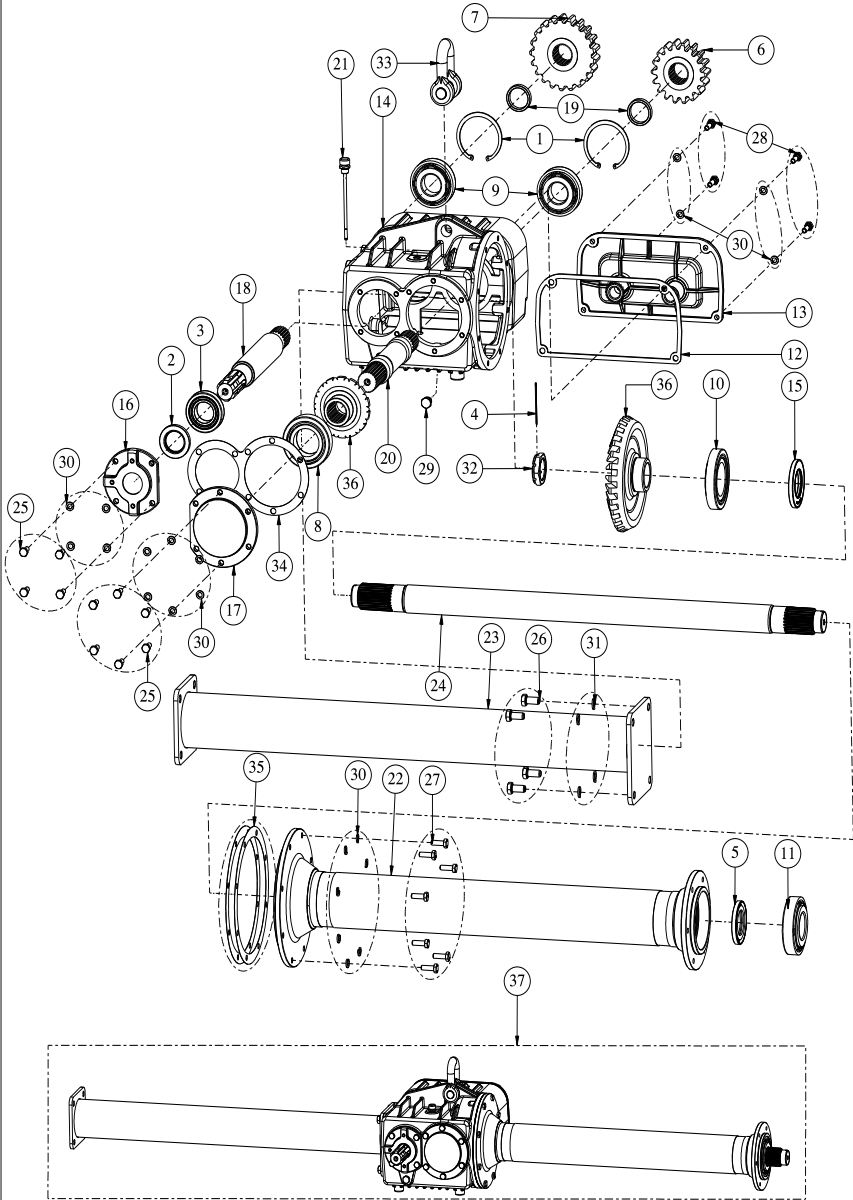

PM1125-21EN-000_REV_005_DEC_20

3.1

GEAR BOX ASSEMBLY PARTS



Sr. No.	Part No.	Description	Qty.
1	1074	CIRCLIP INTERNAL 100MM	2
2	6021	OIL SEAL 45 X 70 X 10	1
3	2624	BEARING 32209	1
4	1571	COTTER PIN (DIA 3.5 X 80)	1
5	14122	OIL SEAL 55 x 90 x 10	1
6	23044	GEAR Z-18	1
	23043	GEAR Z-17	
7	23046	GEAR Z-22	1
	23047	GEAR Z-23	
8	23001	BEARING 32212	1
9	23002	BEARING 30309	2
10	23003	BEARING 30214	1
11	23004	BEARING 30311	1
12	23008	GASKET, GEARBOX COVER	1
13	23011	COVER, GEARBOX HOUSING, REAR	1
14	23012	GEAR BOX	1
15	23050	OIL SEAL 55 X 100 X 10	1
16	23072	FLANGE, INPUT SHAFT	1
17	23073	COVER, GEARBOX HOUSING FRONT	1
18	23090	SHAFT,INPUT 1-3/4" Z-6	1
19	23091	SPACER,GEAR BOX STRAIGHT GEAR	2
20	23092	PINION SHAFT	1
21	23287	DIPSTICK 153MM (M16 X 1.5) (1MLSR204)	1
22	23173	EXTENSION TUBE, TR SIDE (SRT-200)	1
	23290	EXTENSION TUBE,TR SIDE (SRT-250)	
	23230	EXTENSION TUBE ,TR SIDE (SRT-300)	
23	23174	EXTENSION TUBE, EX.SIDE (SRT-200)	1
	23291	EXTENSION TUBE,EX SIDE (SRT-250)	
	23231	EXTENSION TUBE ,EX.SIDE (SRT-300)	
24	23175	SHAFT, OUTPUT 971 MM (SRT-200)	1
	23297	SHAFT, OUTPUT 1226 MM (SRT-250)	
	23237	SHAFT, OUTPUT 1471 MM (SRT-300)	
25	17270	HEX BOLT M10X1.50X25(DIN933)(8.8)(ZP)	10
26	17280	HEX BOLT M14X2.00X30(DIN933)(8.8)(ZP)	4
27	3340	HEX BOLT M10X1.50X30(DIN933)(8.8)(ZP)	8
28	3345	HEX BOLT M10X1.50X35(DIN931)(8.8)(ZP)	4
29	3419	3/8 BSP BOLT WITH O-RING	1
30	14361	SPRING WASHER M10.00(IS 3063)(ZP)	22
31	14363	SPRING WASHER M14.00(IS 3063)(ZP)	4
32	23431	CASTLE NUT M45X1.5, L=16.5	1
33	23484	D-SHACKLE PIN-7/8"	1
34	23049	GASKET, FRONT GEARBOX 0.5 NA	1
35	23051	GASKET,SHAFT BEARINGMOU 0.5 NA	2
36	23522	CROWN T29 PINION T14 PAIR	1
37	23176	GEAR BOX ASSMBLY (200/1000)	1
	23298	GEAR BOX ASSMBLY (250/1000)	
	23238	GEAR BOX ASSMBLY (300/1000)	

END PLATE ASSEMBLY TRASMISSION SIDE

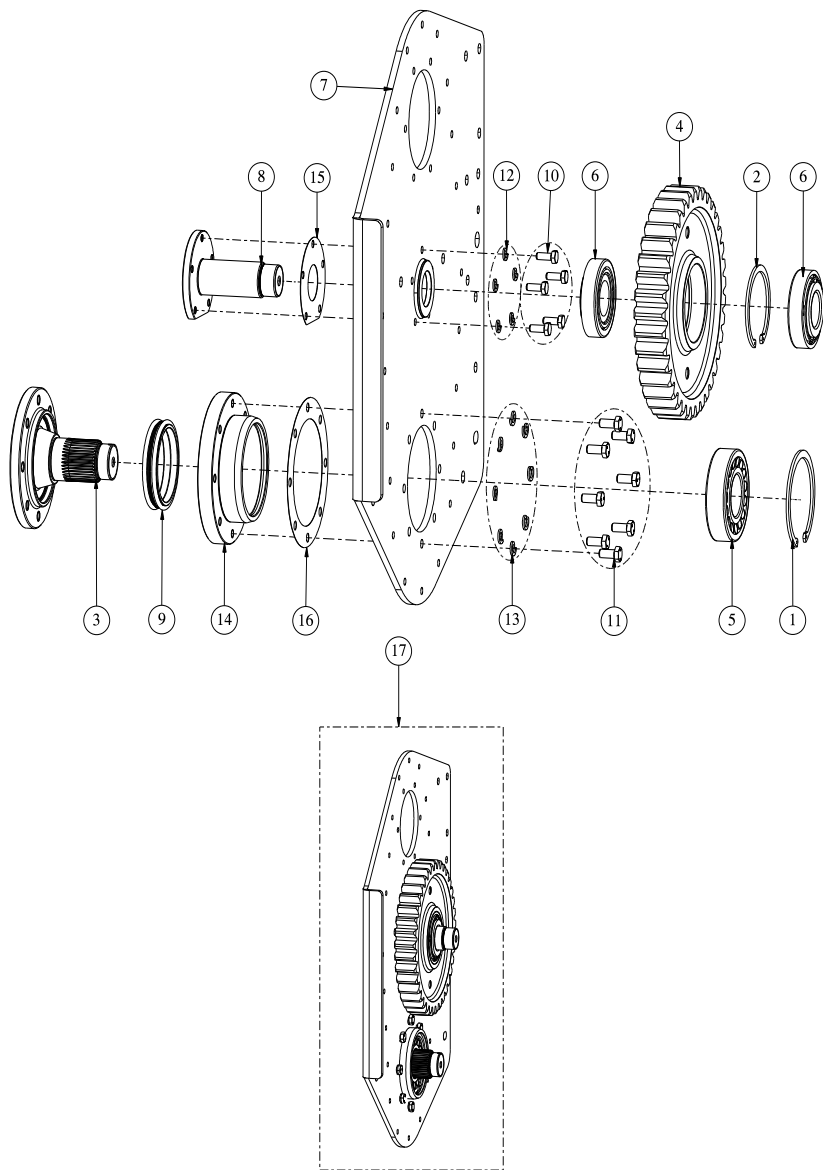

END PLATE ASSEMBLY TRASMISSION SIDE



Sr. No.	Part No.	Description	Qty.
1	2547	INTERNAL CIRCLIP 130MM	1
2	11070	INTERNAL CIRCLIP 110MM	1
3	23034	ROTOR HUB, GEAR DRIVE SIDE	1
4	23038	GEAR, IDLER Z-37	1
5	23005	BEARING 21312-E1	1
6	23006	BEARING 30310	2
7	23076	TILLER END PLATE WELD, GD SIDE	1
8	23096	PIN, IDLE GEAR	1
9	23025	DUO CONE SEAL SAP 122.5 X 104.63 X 22.5	1
10	17270	HEX BOLT M10X1.50X25(DIN933)(8.8)(ZP)	5
11	17474	HEX BOLT M12X1.75X25(DIN933)(8.8)(ZP)	8
12	14361	SPRING WASHER M10.00(IS 3063)(ZP)	5
13	14362	SPRING WASHER M12.00(IS 3063)(ZP)	8
14	23492	BEARING MOUNT.TRASMISSION SIDE	1
15	23054	GASKET, PIN IDLE GEAR 0.5 NA	1
16	23055	GASKET,ROTOR BEARING MOU.TR 0.5 NA	1
17	23097	TILLER END PLATE,TR. SIDE ASM.	1

4.2

PM1125-21EN-000_REV_005_DEC_20

END PLATE ASSEMBLY EXTERNAL SIDE

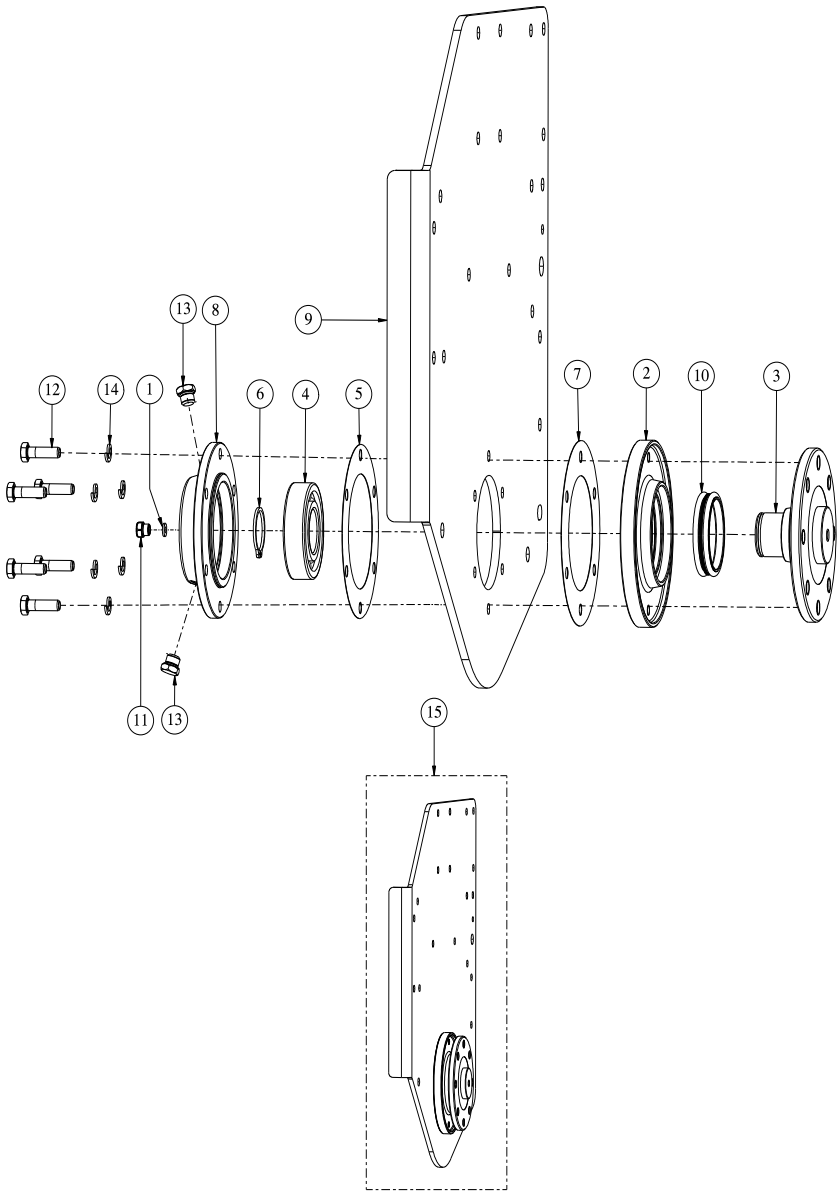

END PLATE ASSEMBLY EXTERNAL SIDE



Sr. No.	Part No.	Description	Qty.
1	20877	DOWTY SEAL 1/4 BSP	1
2	23036	BEARING MOUNT,EXTERNAL SIDE	1
3	23037	ROTOR HUB,EXTERNAL SIDE	1
4	23007	BEARING 6310	1
5	23056	GASKET,ROTOR BEARINGMOU.EX 0.5 NA	1
6	23057	CIRCLIP EXTERNAL 50MM (HEAVY)	1
7	23058	GASKET,BEARING MOUNT COVER 0.5 NA	1
8	23071	BEARING MOUNT COVER-EXTERNAL SIDE	1
9	23098	TILLER END PLATE, EXTERNAL SIDE	1
10	23026	DUO CONE SEAL SAP 92.5 X 80.10 X 20	1
11	14313	OIL LEVEL GAUGE 1/4" BSP (1GTLN110)	1
12	17433	HEX BOLT M12X1.75X40(DIN931)(8.8)(ZP)	6
13	3419	3/8 BSP BOLT WITH O-RING	2
14	14362	SPRING WASHER M12.00(IS 3063)(ZP)	6
15	23099	TILLER END PLATE,EX. SIDE ASM.	1

ROTOR PARTS



ROTOR BLADE - CURVED TYPE

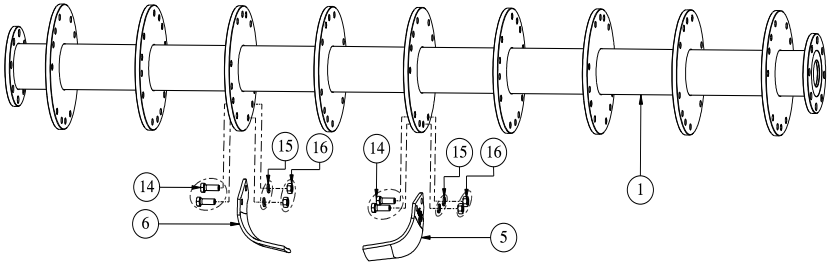

ROTOR BLADE - L TYPE

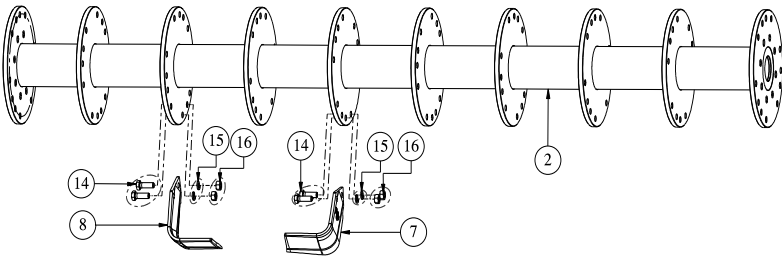

ROTOR SPIKE BLADE

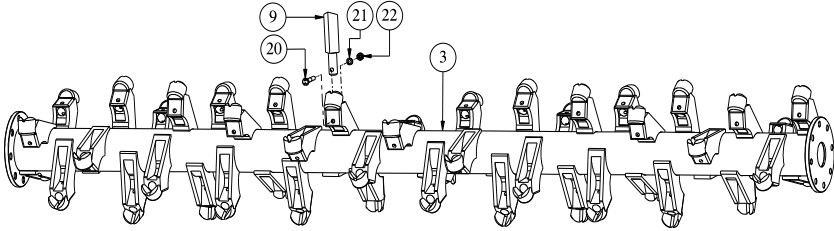

ROTOR STRAIGHT BLADE

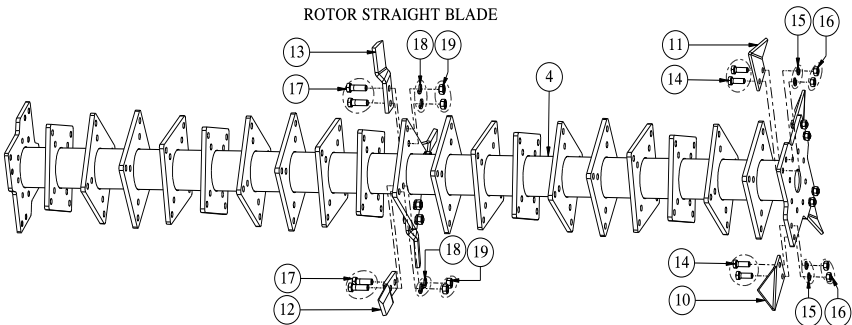

ROTOR PARTS



Sr. No.	Part No.	Description	Qty.
1	23177	ROTOR WELDMENT STANDARD (SRT-200)	1
	23293	ROTOR WELDMENT STANDARD (SRT-250)	
	23233	ROTOR WELDMENT STANDARD (SRT-300)	
2	23178	ROTOR WELDMENT INWARD (SRT-200)	1
	23294	ROTOR WELDMENT INWARD (SRT-250)	
	23234	ROTOR WELDMENT INWARD (SRT-300)	
3	23444	SPIKE ROTOR WELDMENT (SRT-200)	1
	23295	SPIKE ROTOR WELDMENT (SRT-250)	
	23235	SPIKE ROTOR WELDMENT (SRT-300)	
4	23446	BLADE ROTOR WELDMENT (SRT-200)	1
	23296	BLADE ROTOR WELDMENT (SRT-250)	
	23236	BLADE ROTOR WELDMENT (SRT-300)	
5	23159	BLADE CURVED LH (90X8) (180X135)	AS REQ.
6	23160	BLADE CURVED RH (90X8) (180X135)	AS REQ.
7	1374	BLADE L- TYPE LH INDIAN	AS REQ.
8	3029	BLADE L- TYPE RH INDIAN	AS REQ.
9	23224	SPIKE BLADE SQ. 30X30	AS REQ.
10	23380	EXTERNAL BLADE LH (BLADES ROTOR)	AS REQ.
11	23379	EXTERNAL BLADE RH (BLADES ROTOR)	AS REQ.
12	23225	STRAIGHT BLADE 50X12 LH	AS REQ.
13	23226	STRAIGHT BLADE 50X12 RH	AS REQ.
14	14337	HEX BOLT M14X1.50X40(DIN931)(10.9)(ZP)	AS REQ.
15	14363	SPRING WASHER M14.00(IS 3063)(ZP)	AS REQ.
16	14338	HEX NUT M14 X 1.50 (10.9) DIN934	AS REQ.
17	7039	HEX BOLT M16X1.50X50(IS1364-1)(10.9)(ZP)	AS REQ.
18	14364	SPRING WASHER M16.00(IS 3063)(ZP)	AS REQ.
19	6582	HEX NUT M16X1.50(DIN 934)(8)(ZP)	AS REQ.
20	23286	HEX BOLT M10 X 1.25 X 60 (10.9) DIN 960	AS REQ.
21	14361	SPRING WASHER M10.00(IS 3063)(ZP)	AS REQ.
22	6556	HEX NUT M10X1.25(DIN 934)(8)(ZP)	AS REQ.

ROLLER PARTS



SPIKE ROLLER ASM DIA. -540

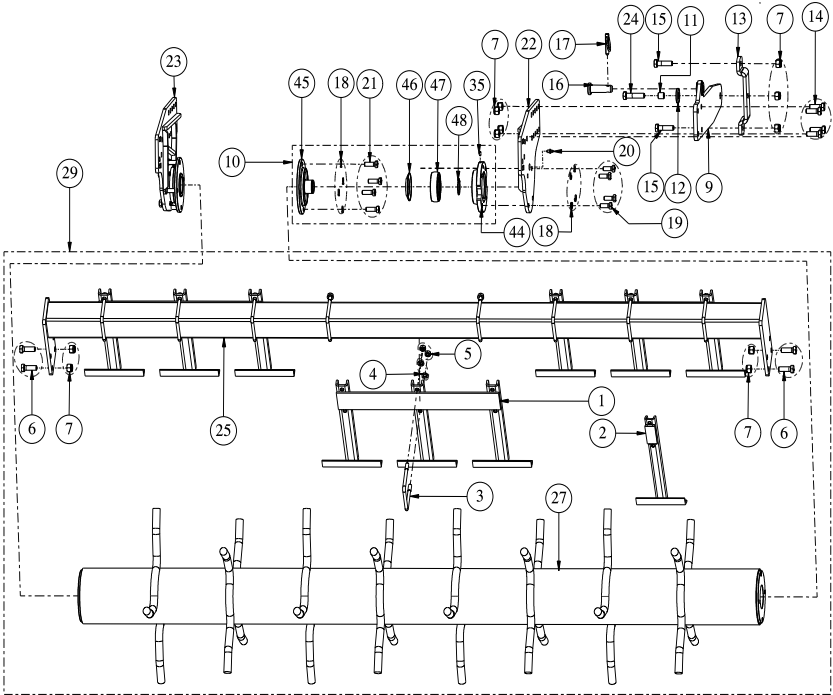

PACKER ROLLER DIA.-500

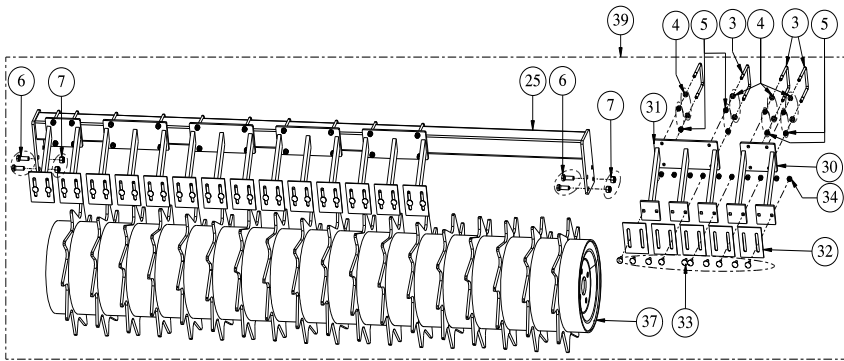

ROLLER PARTS



Sr. No.	Part No.	Description	Qty.
1	23265	SCRAPER WELDMENT, 3-UNITS SRT-200	2
		SCRAPER WELDMENT, 3-UNITS SRT-250	3
		SCRAPER WELDMENT, 3-UNITS SRT-300	4
2	23308	SCRAPER WELDMENT, 1-UNITS SRT-250	1
3	7387	U-BOLT M10X1.25X91X103X25TL (8.8)	AS REQ.
4	8078	PLAIN WASHER 10MM (BS-4320)	AS REQ.
5	6556	HEX NUT M10X1.25(DIN 934)(8)(ZP)	AS REQ.
6	23318	HEX BOLT M14X1.50X40(DIN931)(8.8)(ZP)	AS REQ.
7	1302	NYLOCK NUT M14X1.50 (DIN-982)	AS REQ.
8	6663	SELF LOCK NUT M12 X 1.25 DIN 980V (SPIKE ROLLER) (SRT-250,SRT-300)	8
		SELF LOCK NUT M12 X 1.25 DIN 980V (CAGE ROLLER)	
9	23242	ROLLER ARM WELDMENT	2
10	23284	MOUNTING SUPPORT ROLLER COMP.	2
11	23020	BUSHING, ROLLER ARM	2
12	23244	SPACER - 44 X 19 X 6	2
13	23119	BRACKET, ROLLER ARM	2
14	3341	HEX BOLT M14X1.50X40(DIN933)(8.8)(ZP)	8
15	3344	HEX BOLT M14X1.50X50(DIN931)(8.8)(ZP)	4
16	23381	PIN, JACK MOUNTING	2
17	23062	LINCH PIN (D10XL45)	2
18	1306	SPRING WASHER M12.00(IS 3063)	16
19	6587	HEX BOLT M12 X 1.25 X 30 DIN 961 - 8.8	8
20	6559	GREASE NIPPLE M8 X 1	2
21	6589	HEX BOLT M12 X 1.25 X 35 DIN 961 - 8.8	8
22	23388	RIGHT END PLATE WELD, FRAME ROLL.	1
23	23389	LEFT END PLATE WELD, FRAME ROLL.	1
24	23382	HEX BOLT M14X1.50X60(DIN931)(8.8)(ZP)	2
25	23409	TUBE WELDMENT SCRAPER (SRT-200)	1
	23306	TUBE WELDMENT SCRAPER (SRT-250)	
	23263	TUBE WELDMENT SCRAPER (SRT-300)	
26	23412	SPIKE ROLLER WELD D490 (SRT-200)	1
	23305	SPIKE ROLLER WELD D490 (SRT-250)	
	23262	SPIKE ROLLER WELD D490 (SRT-300)	
27	23410	SPIKE ROLLER WELD D540 (SRT-200)	1
	23307	SPIKE ROLLER WELD D540 (SRT-250)	
	23264	SPIKE ROLLER WELD D540 (SRT-300)	
28	23413	KIT SPIKE ROLLER ASM D490 (SRT-200)	1
	23309	KIT SPIKE ROLLER ASM D490 (SRT-250)	
	23266	KIT SPIKE ROLLER ASM D490 (SRT-300)	
29	23411	KIT SPIKE ROLLER ASM D540 (SRT-200)	1
	23310	KIT SPIKE ROLLER ASM D540 (SRT-250)	
	23267	KIT SPIKE ROLLER ASM D540 (SRT-300)	
30	23269	SCRAPER WELDMENT (DOUBLE SCRAPER) (SRT-200)	1
		SCRAPER WELDMENT (DOUBLE SCRAPER) (SRT-250)	3
		SCRAPER WELDMENT (DOUBLE SCRAPER) (SRT-300)	2

ROLLER PARTS

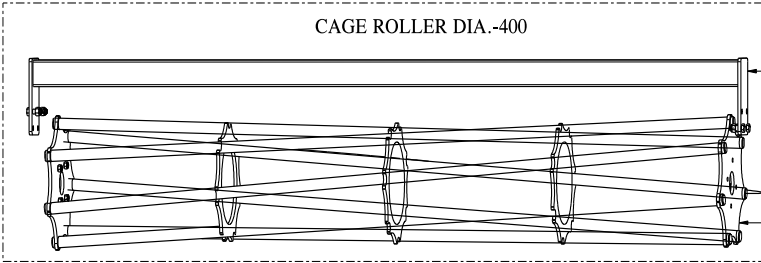
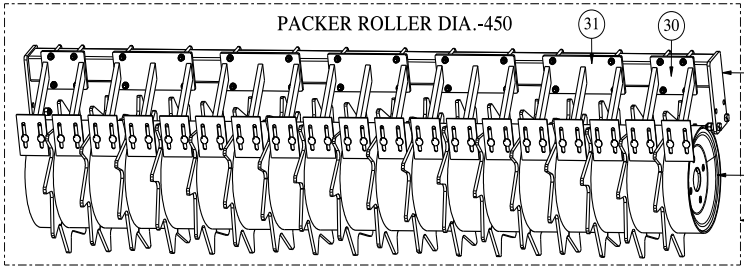
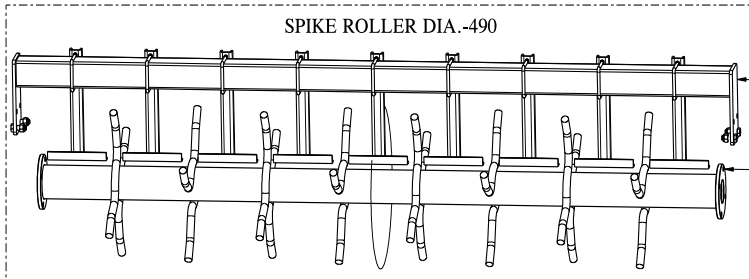
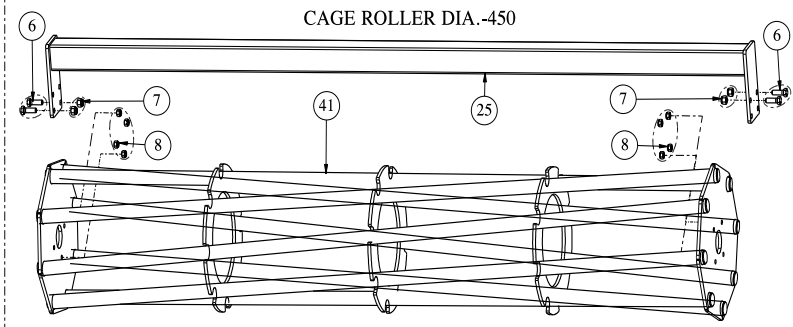

ROLLER PARTS



Sr. No.	Part No.	Description	Qty.
31	23270	SCRAPER WELDMENT (TRIPLE SCRAPER) (SRT-200)	5
		SCRAPER WELDMENT (TRIPLE SCRAPER) (SRT-250)	5
		SCRAPER WELDMENT (TRIPLE SCRAPER) (SRT-300)	7
32	23271	SCRAPER PLATE, PACKER ROLLER (SRT-200)	17
		SCRAPER PLATE, PACKER ROLLER (SRT-250)	21
		SCRAPER PLATE, PACKER ROLLER (SRT-300)	25
33	8175	RO HD SQ NECK BOLT M10 X 1.5 X 25 FT-8.8 SRT-200	AS REQ.
34	1298	NYLOCK NUT M10X1.50 (DIN-982) SRT-200	AS REQ.
35	12090	GRUB SCREW M6 X 1 X 10	2
36	23417	PACKER ROLLER WELD D450 (SRT-200)	1
	23311	PACKER ROLLER WELD D450 (SRT-250)	
	23268	PACKER ROLLER WELD D450 (SRT-300)	
37	23419	PACKER ROLLER WELD D500 (SRT-200)	1
	23322	PACKER ROLLER WELD D500 (SRT-250)	
	23320	PACKER ROLLER WELD D500 (SRT-300)	
38	23418	KIT PACKER ROLLER ASM. D450 (SRT-200)	1
	23312	KIT PACKER ROLLER ASM. D450 (SRT-250)	
	23272	KIT PACKER ROLLER ASM. D450 (SRT-300)	
39	23420	KIT PACKER ROLLER ASM. D500 (SRT-200)	1
	23323	KIT PACKER ROLLER ASM. D500 (SRT-250)	
	23321	KIT PACKER ROLLER ASM. D500 (SRT-300)	
40	23423	CAGE ROLLER WELDMENT D400 (SRT-200)	1
	23313	CAGE ROLLER WELDMENT D400 (SRT-250)	
	23273	CAGE ROLLER WELDMENT D400 (SRT-300)	
41	23421	CAGE ROLLER WELDMENT D450 (SRT-200)	1
	23329	CAGE ROLLER WELDMENT D450 (SRT-250)	
	23327	CAGE ROLLER WELDMENT D450 (SRT-300)	
42	23424	KIT CAGE ROLLER ASM D400 (SRT-200)	1
	23314	KIT CAGE ROLLER ASM D400 (SRT-250)	
	23274	KIT CAGE ROLLER ASM D400 (SRT-300)	
43	23422	KIT CAGE ROLLER ASM D450 (SRT-200)	1
	23330	KIT CAGE ROLLER ASM D450 (SRT-250)	
	23328	KIT CAGE ROLLER ASM D450 (SRT-300)	
44	23281	BEARING SUPPORT	2
45	23282	HUB SUPPORT ROLLER	2
46	23283	DUST RING	2
47	23386	Y-BEARING 6308-2RS1	2
48	8027	CIRCLIP EXTERNAL 40MM	2

HYDRAULIC JACK, MECHANICAL JACK AND LEVELING BAR ASSEMBLY

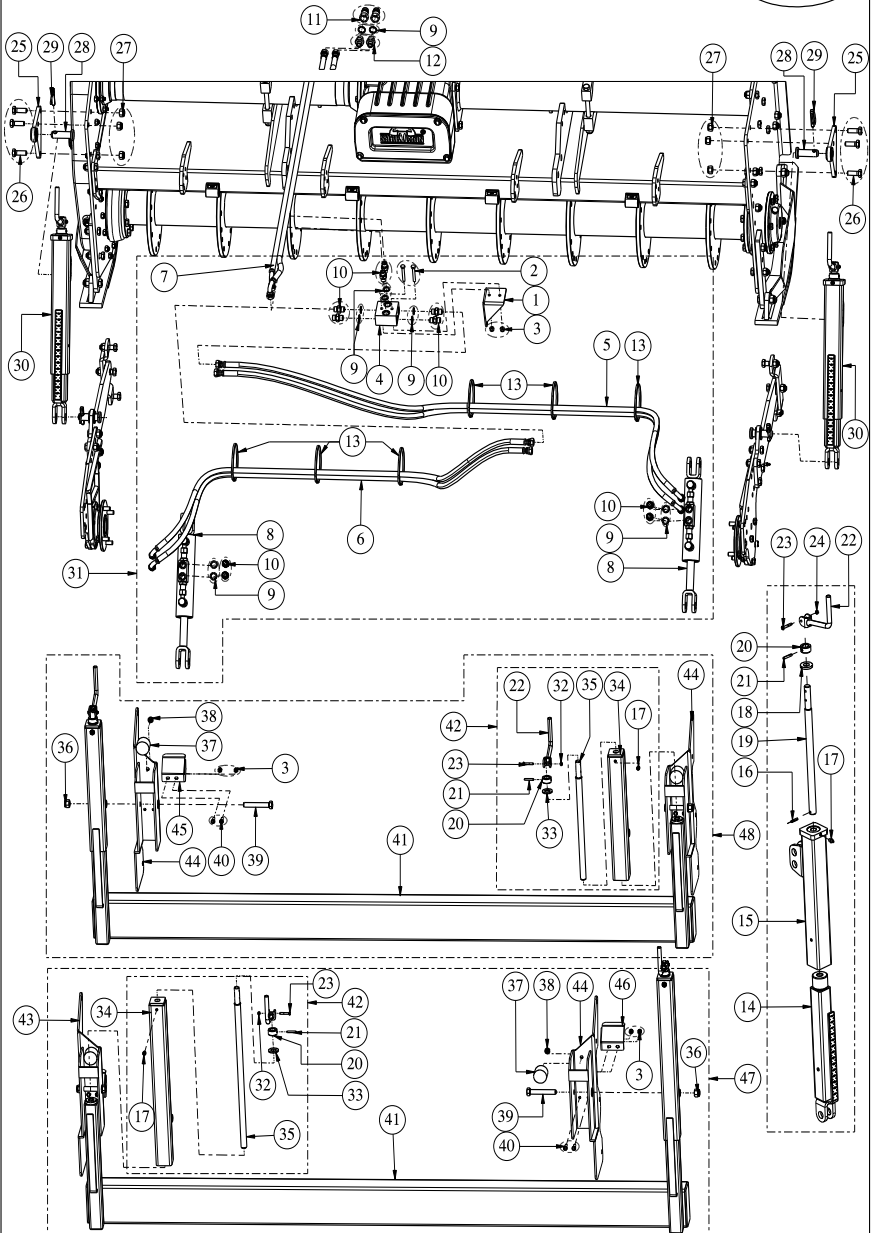

PM1125-21EN-000_REV_005_DEC_20

8.1

HYDRAULIC JACK, MECHANICAL JACK AND LEVELING BAR ASSEMBLY



Sr. No.	Part No.	Description	Qty.
1	23153	BRACKET, HYDRAULIC VALVE SUPPORT	1
2	19164	HEX BOLT M8X1.25X60(S1364-2)(8.8)(ZP)	2
3	1297	NYLOCK NUT M8X1.25 (DIN-982)	2
		NYLOCK NUT M8X1.25 (DIN-982) (FOR LEVELING BAR)	4
4	23015	HYD. DISTRIBUTOR VALVE 3/8"	1
5	23016	HYD. HOSE R1AT, F90° 3/8" FD3/8", L=2300	2
6	23018	HYD. HOSE R1AT, F90° 3/8"-FD 3/8", L=1900	2
7	23019	HYD. HOSE R1AT F90° 3/8"-FD 3/8", L=1600	2
8	23223	HYD. CYLINDER 385X535 WITH CHECK VALVE	2
9	19007	DOWTY SEAL (3/8 BSP)	12
10	9553	NIPPLE 3/8" BSP STD	10
11	9563	HYD. MALE COUPLING 1/2" BSP	2
12	18241	HEX NIPPLE (1/2" X 3/8" STD)	2
13	23390	CABLE TIE 400MM	4
14	23276	MECH. JACK WELDMENT, INTERNAL	2
15	23277	MECH. JACK WELDMENT, EXTERNAL	2
16	23278	SPRING PIN D6X26	2
17	6559	GREASE NIPPLE M8 X 1	2
18	23391	WASHER 40 X 19 X 6 MM	2
19	23392	ADJUSTING THREADED BAR	2
20	6550	BUSHING MECH. JACK (SPH-120)	2
21	25195	DOWEL PIN 6 X 36 (ISO8752)	2
22	6549	HANDLE WELD. (SPH-120)	2
23	6601	HEX BOLT M6X1.00X35(DIN931)(8.8)(ZP)	2
24	6583	HEX NUT M6X1.00(DIN 934)(8)(ZP)	2
25	23245	MOUNTING, JACK COUPLING WELD.	2
26	23318	HEX BOLT M14X1.50X40(DIN931)(8.8)(ZP)	6
27	1302	NYLOCK NUT M14X1.50 (DIN-982)	6
28	23381	PIN, JACK MOUNTING	2
29	23062	LINCH PIN (D10XL45)	2
30	23279	MECHANICAL JACK ASSEMBLY	2

HYDRAULIC JACK, MECHANICAL JACK AND LEVELING BAR ASSEMBLY

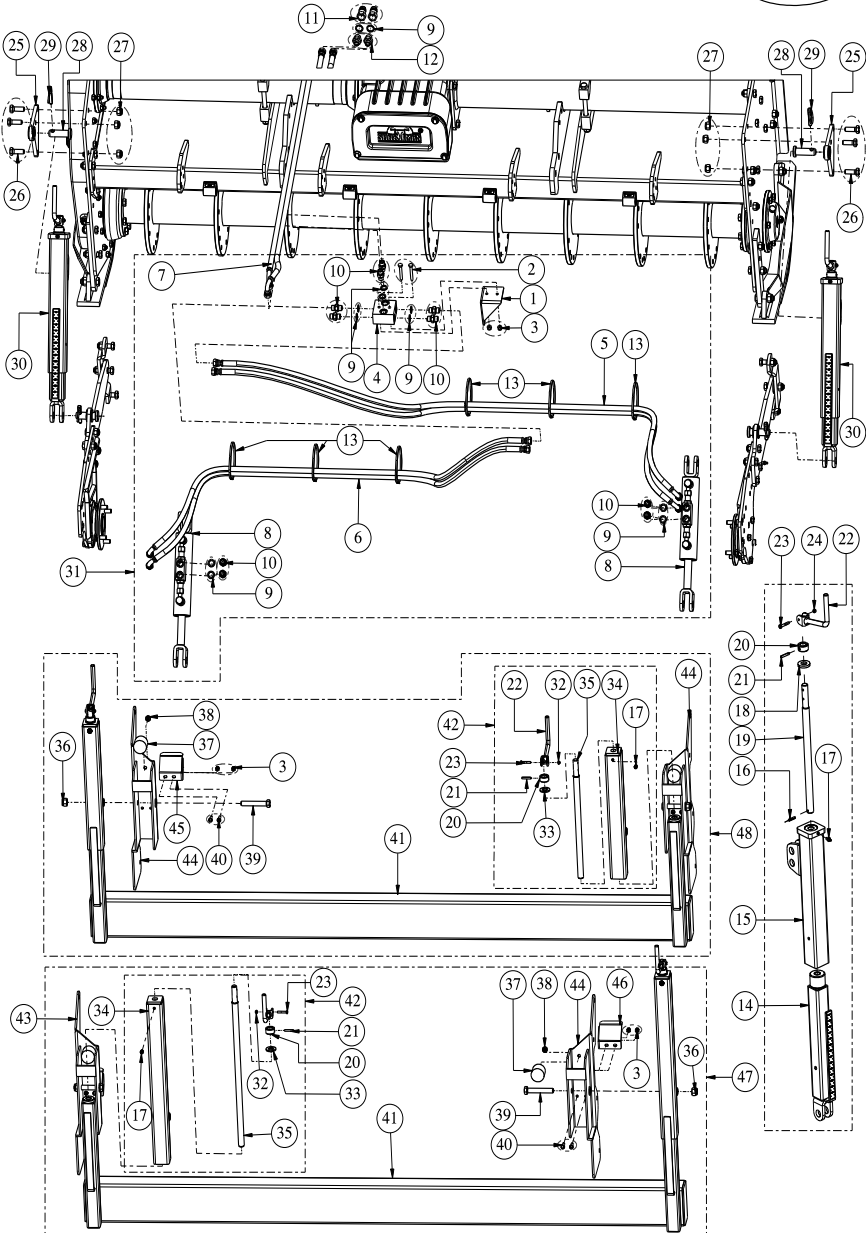

PM1125-21EN-000_REV_005_DEC_20

8.1

HYDRAULIC JACK, MECHANICAL JACK AND LEVELING BAR ASSEMBLY



Sr. No.	Part No.	Description	Qty.
31	23280	KIT HYD. JACK ASM. 300	1
	23326	KIT HYD. JACK ASM. 250	
32	19140	NYLOCK NUT M6X1.00 (DIN-982)	2
33	17040	PLAIN WASHER 20MM (BS-4320)	2
34	23247	MECHANICAL JACK WELD,UPPAR L=470	2
	23253	MECHANICAL JACK WELD,UPPAR L=610	
35	23249	THEADED BAR, MECH. JACK L=470	2
	23254	THEADED BAR, MECH. JACK L=610	
36	1231	NYLOCK NUT M16X2.0 (DIN-982)	2
37	6546	BUMPER M10X1.5X40 (SPH-120)	2
38	1298	NYLOCK NUT M10X1.50 (DIN-982)	2
39	2208	HEX BOLT M16X2.00X100 (IS1364-2)(8.8)(ZP)	2
40	8171	HEX BOLT M8X1.25X25 (IS1364-2)(8.8)(ZP)	4
41	23414	LEVELING BAR WELDMENT (SRT-200)	1
	23302	LEVELING BAR WELDMENT (SRT-250)	
	23246	LEVELING BAR WELDMENT (SRT-300)	
42	23252	MECHANICAL JACK ASM. UPPAR L=470	2
	23255	MECHANICAL JACK ASM. UPPAR L=610	
43	23256	LEVELING BAR SUPPORT, WELD. RH	1
44	23257	LEVELING BAR SUPPORT, WELD. LH	1
45	23259	PROTECTION, LEVELING BAR RH	1
46	23258	PROTECTION, LEVELING BAR LH	1
47	23416	REAR LEVELING BAR ASM (MECH) (SRT-200)	1
	23303	REAR LEVELING BAR ASM (MECH) (SRT-250)	
	23260	REAR LEVELING BAR ASM (MECH) (SRT-300)	
48	23415	REAR LEVELING BAR ASM (HYD) (SRT-200)	1
	23304	REAR LEVELING BAR ASM (HYD) (SRT-250)	
	23261	REAR LEVELING BAR ASM (HYD) (SRT-300)	

CE KIT AND SHORT REAR BOARD ASSEMBLY

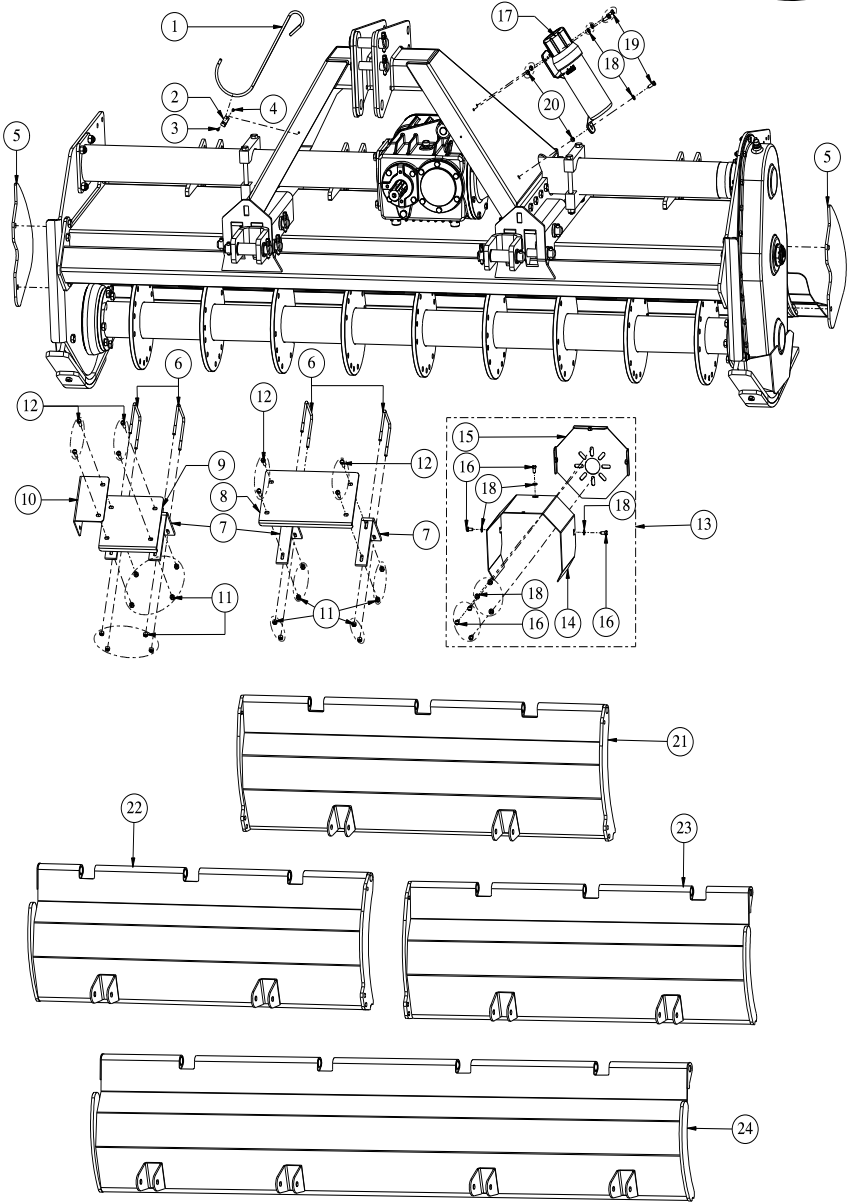

CE KIT AND SHORT REAR BOARD ASSEMBLY



Sr. No.	Part No.	Description	Qty.
1	23146	DRIVELINE HOOK 370MM	1
2	23147	PLATE,HOOK HOLDING	1
3	35098	HEX BOLT M4X0.75X15(IS1364-2)(8.8)(ZP)	1
4	24529	NYLOCK NUT M4 X 0.75 - SCH	1
5	23148	CE SIDE SHIELD	2
6	23496	U-BOLT M8X1.25X100X114X30TL (8.8) (SRT-200)	6
		U-BOLT M8X1.25X100X114X30TL (8.8) (SRT-250)	8
		U-BOLT M8X1.25X100X114X30TL (8.8) (SRT-300)	10
7	23149	BRACKET,FRONT BARRIER (SRT-200)	10
		BRACKET,FRONT BARRIER (SRT-250)	6
		BRACKET,FRONT BARRIER (SRT-300)	6
		PLATE,BARRIER FRONT (L=330) (SRT-250)	2
		PLATE,BARRIER FRONT (L=330) (SRT-300)	4
		PLATE,BARRIER FRONT (L=205) (SRT-200)	3
9	23325	PLATE,BARRIER FRONT (L=205) (SRT-250)	2
		PLATE,BARRIER FRONT (L=205) (SRT-300)	1
10	23151	PLATE,END,FRONT BARRIER	2
11	1297	NYLOCK NUT M8X1.25 (DIN-982) (SRT-200)	24
		NYLOCK NUT M8X1.25 (DIN-982) (SRT-250)	32
		NYLOCK NUT M8X1.25 (DIN-982) (SRT-300)	40
12	8171	HEX BOLT M8X1.25X25(IS1364-2)(8.8)(ZP) (SRT-200)	12
		HEX BOLT M8X1.25X25(IS1364-2)(8.8)(ZP) (SRT-250)	16
		HEX BOLT M8X1.25X25(IS1364-2)(8.8)(ZP) (SRT-300)	20
13	23140	PTO SHAFT GUARD ASSEMBLY	1
14	23387	PTO SHAFT GUARD	1
15	23168	PTO SHAFT GUARD MOUNT PLATE COMP	1
16	8190	HEX BOLT M8X1.25X15(IS1364-2)(8.8)(ZP)	9
17	26030	MANUAL BOX COVER 1/2	1
18	8064	PLAIN WASHER 8MM (BS-4320)	9
19	8040	HEX BOLT M8X1.25X20(IS1364-2)(8.8)(ZP)	3
20	8181	HEX NUT M8X1.25(IS 1363)(8)(ZP)	3
21	23426	SHORT REAR BOARD WELD. ROLLER (SRT-200)	2
	23299	SHORT REAR BOARD WELD. ROLLER (SRT-250)	
	23239	SHORT REAR BOARD WELD. ROLLER (SRT-300)	
22	23300	SHORT REAR BOARD WELD. LEV.LH (SRT-250)	1
	23240	SHORT REAR BOARD WELD. LEV.LH (SRT-300)	
23	23301	SHORT REAR BOARD WELD. LEV.RH (SRT-250)	1
	23241	SHORT REAR BOARD WELD. LEV.RH (SRT-300)	
24	23427	SHORT REAR BOARD WELD. LEV. (SRT-200)	1



J.S. Woodhouse Co., Inc.

1314 Union Street
West Springfield, MA 01089

Tel: 413-736-5462

FAX 413- 732-3786